

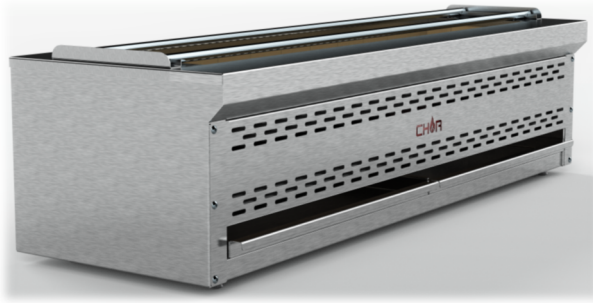

ITEM NO	
QUANTITY	
JOB NAME	
JOB NO	

THE ROBATA



MODEL CP-S182-15

AVAILABLE MODELS

- CP-S182-9XX
- CP-S182-12XX
- CP-S182-15XX
- CP-S182-18XX

*note: XX to identify required fuel type.

SPECIFICATIONS

Gas fueled, all Stainless Steel, Robata Grill; currently available in 24" [600mm], 36" [900mm], 48" [1200mm], 60" [1500mm], 72" [1800mm] Ceramic Fire brick lining, Ceramic Insulated exterior, heavy duty radiants and Full 304 Stainless Steel construction insure performance and longevity of the product. These units come standard on 1" HD adjustable legs and includes a Grill Cleaning kit.

STANDARD FEATURES

- 14 GAUGE STAINLESS STEEL BODY.
- CERAMIC INSULATED.
- RADIANT BURNERS
- FULLY WELDED 14 GA STAINLESS STEEL FIRE BOX.
- FIRE BRICK LINED ON SOLID FUEL MODELS
- 1/2" THICK LASER CUT REMOVABLE STEEL GRATES.
- HEAVY DUTY 1" ADJUSTABLE LEGS.
- ONE YEAR PARTS AND LABOR WARRANTY.

OPTIONS

- 6" ADJUSTABLE LEGS
- NATURAL GAS—NG
- PROPANE—PR



CHAR Products, LLC

Ph. 702-489-9888
Fax. 702-489-9898

CONSULTANT APPROVAL:

NOTES:

DATE:

Website: www.charprd.com 2915 Losee Rd. Ste 106
Email: info@charprd.com N. Las Vegas, NV 89030



MODEL NO.	LENGTH		TOTAL BTU INPUT	SHIP WEIGHT
CP-S182-9XX	36" [900mm]		47000 NG	260 LBS/ 118 kg
CP-S182-12XX	48" [1200mm]		78,000 NG	360 LBS/ 163 kg
CP-S182-15XX	60" [1500mm]		85,000 NG	425 LBS/ 193kg
CP-S182-18XX	72" [1800mm]		100,000 NG	500 LBS/ 227kg

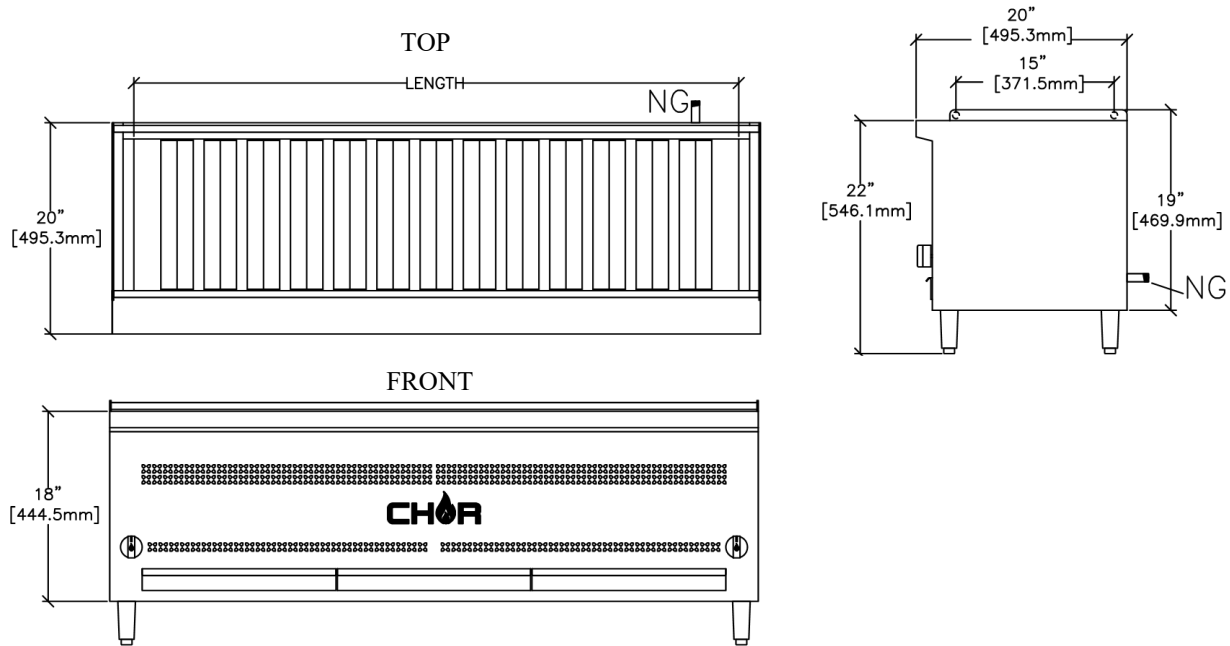

INSTALLATION INSTRUCTIONS

1. A properly sized gas line must be provided. All units are internally regulated. DO NOT DUAL REGULATE.
2. An adequate ventilation system is required for commercial use. DO NOT ATTEMPT TO OPERATE THIS EQUIPMENT WITHOUT IT.
3. Observe all Local and national codes.
4. Proper combustion requires this unit to remain on casters or legs. If a curb installation is preferred please contact CHAR products for information in doing so.
5. This appliance is manufactured for commercial use ONLY. It is NOT intended for Residential indoor use.

CHAR Products, LLC

Ph. 702-489-9888
Fax. 702-489-9898

Website: www.charprd.com 2915 Losee Rd, Ste 106
Email: info@charprd.com N. Las Vegas, NV 89030