



EQUIPMENT BASE REFRIGERATED

SPECIFICATION SHEET

ITEM NO	
QUANTITY	
JOB NAME	
JOB NO	

PART NUMBER DESIGNATION

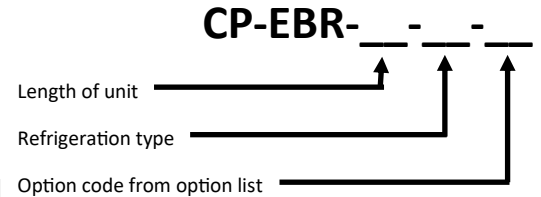

STANDARD FEATURES

- Stainless steel interior and exterior
- Foamed in place high density CFC Free Polyurethane insulation
- Heavy duty 6" adjustable legs
- Digital temperature control
- Doors or drawers include full perimeter magnetic gaskets
- Stainless steel adjustable wire shelf included with door models
- Full extension slide assemblies included with drawer models
- Solid sub top
- Two year warranty parts and labor
- Five year warranty compressor

OPTIONS	
OPTION	DESCRIPTION
C	FOUR 6" ROLLING CASTERS TWO LOCKING
DR	DOORS
DRW	DRAWERS
FCI	FIBER CERAMIC INSULATE TOP

*SHOWN WITH OPTIONAL CASTERS

SPECIFICATIONS

CHAR Products has over 20 years experience designing, engineering and manufacturing Freezer Equipment Bases. Our products reside all over the United States, in some of the most prestigious establishments.

Contact our sales team and see what we can do for your next Freezer Equipment Base project.

- Must select length 36",48",60"72"
- Must select refrigeration type (SC) self contained (RR) remote refrigeration
- Self contained will be R404A/R448A refrigerant standard

*



CONSULTANT APPROVAL:

CHAR Products, LLC

Ph. 702-489-9888

Fax. 702-489-9898

Website: www.charprd.com

Email: info@charprd.com

2915 Losee Rd. Ste 106

N. Las Vegas, NV 89030

© copyright 2024



MODEL #	LENGTH A	ELECTRIC	BTU H	SHIPPING WEIGHT ESTIMATED
CP-EBR-36-__-__-__	36"	120V-1PH-10A	1100	350 LBS.
CP-EBR-48-__-__-__	48"	120V-1PH-10A	1300	375 LBS.
CP-EBR-60-__-__-__	60"	120V-1PH-10A	1500	400 LBS.
CP-EBR-72-__-__-__	72"	120V-1PH-10A	1700	450 LBS.

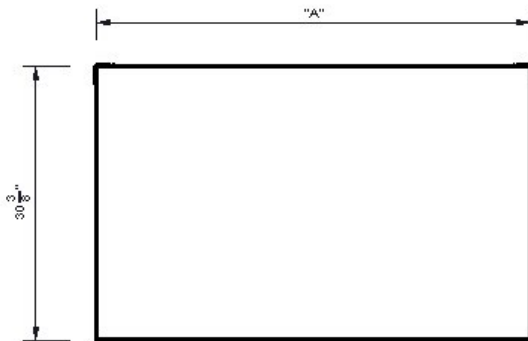

TOP

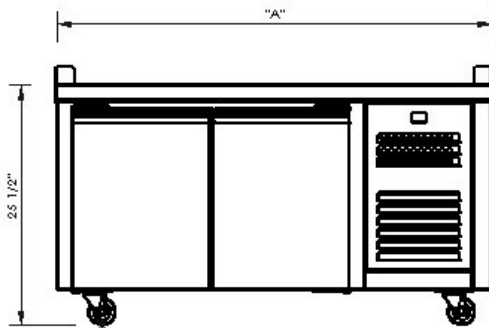

FRONT

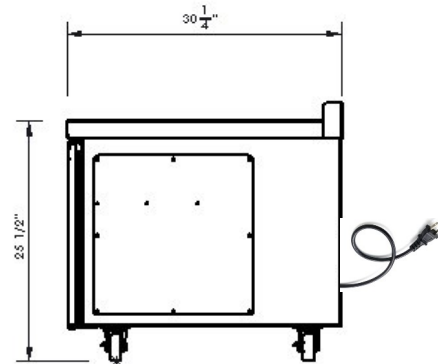

SIDE

INSTALLATION INSTRUCTIONS

1. Observe all local and national codes.
2. This appliance is manufactured for commercial use ONLY. It is NOT intended for residential indoor use.
3. We upgrade our products regularly and in doing so, materials, specifications, and model numbers are subject to change without notice.

CHAR Products, LLC

Ph. 702-489-9888

Fax. 702-489-9898

Website: www.charprd.com

Email: info@charprd.com

2915 Losee Rd. Ste 106

N. Las Vegas, NV 89030