



ROUND ROTATING BROILER

SPECIFICATION SHEET



ITEM NO	
QUANTITY	
JOB NAME	
JOB NO	

PART NUMBER DESIGNATION

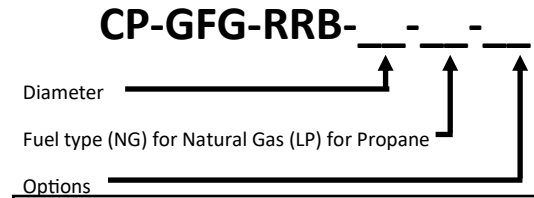

STANDARD FEATURES

- 14 Gauge stainless steel body
- Left and right side gas valves
- Removable drip pans
- Fully welded 14 gauge stainless steel fire box
- Ceramic cloth insulated perimeter
- 1/2" Thick laser cut removable steel grates
- Heavy duty locking swivel casters
- 1" gas connection
- Appropriate regulator for gas type selection
- Two year warranty parts and labor

OPTIONS

OPTION CODE	DESCRIPTION
GP	1/2" POLISHED GRIDDLE PLATE
FQD	48" GAS FLEX QUICK DISCONNECT
RPS	REMOVABLE PLATE SHELF 10"
PSC	PLATE SHELF 1/6 PAN W/CONDIMENT INSERT
FF	FEATURE FLAME

SPECIFICATIONS

The CHAR Round Broiler uses gas fuel. Available in 38", 48" and 60" diameters. The unit serves as a heavy duty broiler and can function as a griddle when equipped with the high polished 1" thick removable stainless steel griddle plates. These units are equipped with heavy duty cast lift out burners and radiant panels. To ensure peak performance and longevity, these units are constructed entirely from 304 stainless steel and contain a ceramic cloth insulated exterior.

- Must select diameter 48,60 inch diameters
- Must select fuel type (NG) for Natural Gas (LP) for Propane



CONSULTANT APPROVAL:



MODEL #	DIAMETER A	HEIGHT	ELECTRICAL	ELECTRICAL	BTU INPUT NG	BTU W/ FEATURE FLAME	SHIPPING WEIGHT ESTIMATED
CP-GFG-RRB-48-__	48"	36.5"	120V-1PH-8A	120V-1PH-10A	198,000	228,000	1,200 LBS.
CP-GFG-RRB-60-__	60"	36.5"	120V-1PH-8A	120V-1PH-10A	222,000	252,000	1,550 LBS.

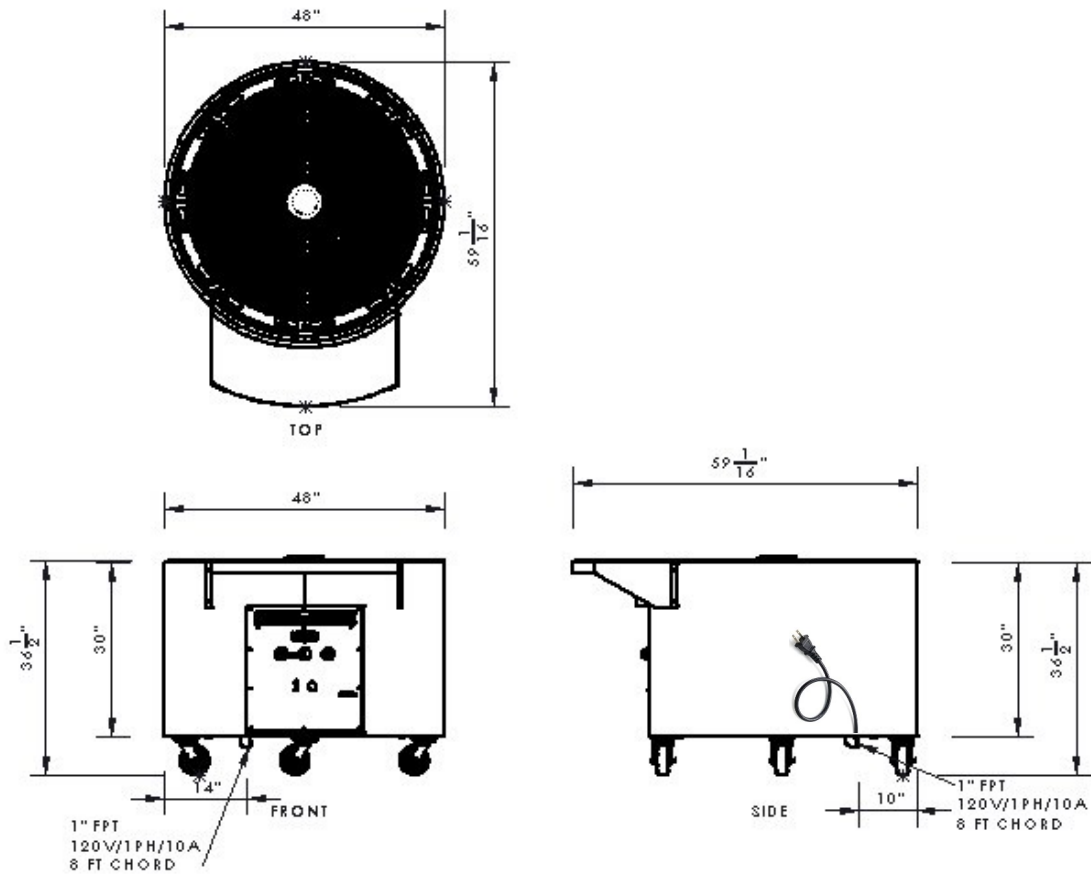

INSTALLATION INSTRUCTIONS

1. A properly sized gas line must be provided. All units are internally regulated. DO NOT DUAL REGULATE.
2. An adequate ventilation system is required for commercial use. DO NOT ATTEMPT TO OPERATE THIS EQUIPMENT WITHOUT IT.
3. Observe all local and national codes.
4. Proper combustion requires this unit to remain on 6" casters
5. This appliance is manufactured for commercial use ONLY. It is NOT intended for residential indoor use.
6. We upgrade our products regularly and in doing so, materials, specifications, and model numbers are subject to change without notice.

CHAR Products, LLC

Ph. 702-489-9888

Fax. 702-489-9898

Website: www.charprd.com

Email: info@charprd.com

2915 Losee Rd. Ste 106

N. Las Vegas, NV 89030