

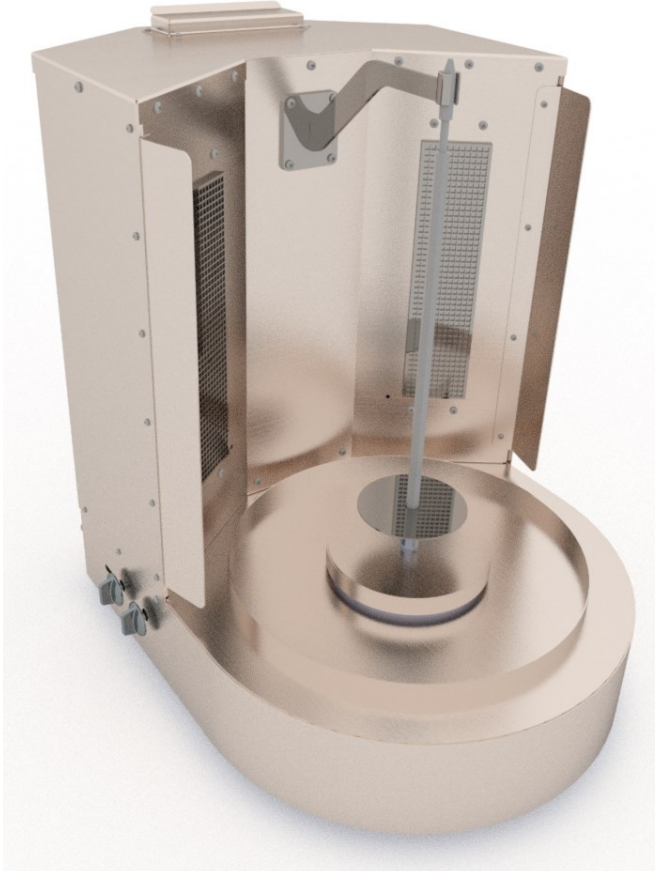

VERTICAL ROTISSERIE

SPECIFICATION SHEET



SPECIFICATIONS

The CHAR Vertical Rotisserie is engineered for simple and secure skewer installation and removal. Gas Fueled, this infrared heat source is available in 33"x22". Smooth gear drive motion and offset heat sources provide uniform coverage of all available cooking area. The fully insulated exterior façade and interior base to ensure safe operation. Heavy duty stainless steel construction provides stability and longevity of the Vertical Rotisserie

- Must select gas type (LP) for Propane (NG) for Natural Gas

ITEM NO	
QUANTITY	
JOB NAME	
JOB NO	

PART NUMBER DESIGNATION

CP-GFG-VRTROT- -

Gas type (LP) for Propane (NG) for Natural Gas

Option code from option list

STANDARD FEATURES

- Full stainless steel construction
- Fully insulated, both interior and exterior
- Custom turned spit assembly includes 2 ea
- Full gas safety
- Removable drip pan
- Adjustable leveling feet
- 45 lb. spit capacity
- 3/4" gas connection
- Adjustable leveling feet
- Appropriate gas regulator (for gas type selected)
- Two year warranty parts and labor

OPTIONS

OPTION CODE	DESCRIPTION
FHS	FOLD OUT HEAT SHIELDS
E120V	ELECTRICAL 120V/750W
E240V	ELECTRICAL 240V/750W
SA	SKEWER ASSEMBLY

CONSULTANT APPROVAL:



CHAR Products, LLC

Ph. 702-489-9888

Fax. 702-489-9898

Website: www.charprd.com

Email: info@charprd.com

2915 Losee Rd. Ste 106

N. Las Vegas, NV 89030

© copyright 2024



MODEL #	LENGTH	WIDTH	FUEL LINE SIZE	ELECTRIC W/GAS SAFETY	BTU INPUT	SHIPPING WEIGHT ESTIMATED
CP-GFG-VRTROT-__-__	32 5/8"	31 5/16"	3/4"	120V-1PH-10A	65,000	350 LBS.

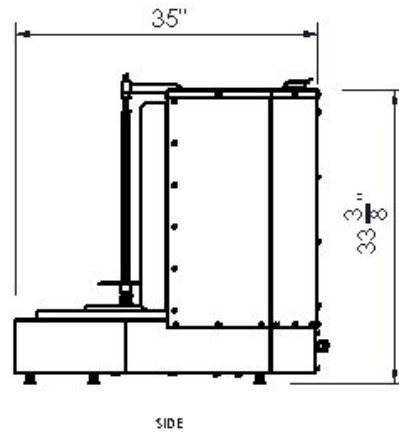
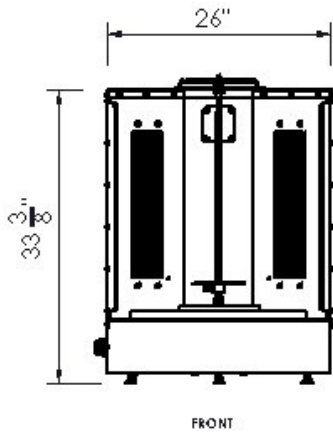
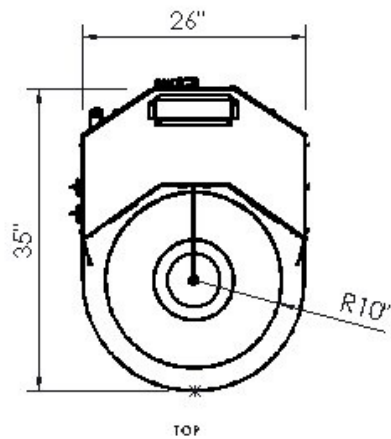

INSTALLATION INSTRUCTIONS

1. A properly sized gas line must be provided. All units are internally regulated. DO NOT DUAL REGULATE.
2. An adequate ventilation system is required for commercial use. DO NOT ATTEMPT TO OPERATE THIS EQUIPMENT WITHOUT IT.
3. Observe all local and national codes.
4. Proper combustion requires this unit to remain on 3" legs.
5. This appliance is manufactured for commercial use ONLY. It is NOT intended for residential indoor use.
6. We upgrade our products regularly and in doing so, materials, specifications, and model numbers are subject to change without notice.

CHAR Products, LLC

Ph. 702-489-9888

Fax. 702-489-9898

Website: www.charprd.com

Email: info@charprd.com

2915 Losee Rd. Ste 106

N. Las Vegas, NV 89030