



SANTA MARIA SOLID FUEL GRILL

SPECIFICATION SHEET



SPECIFICATIONS

The CHAR solid fuel Santa Maria Grill is manufactured to precise standards using 304 stainless steel full body construction and heavy duty support frame. Operator safety and comfort is strengthened through the use of ceramic lined exterior panels that prevent heat transfer. Enhanced cooking performance is achieved through the use of refractory brick lined burn pit with tailgate style access for easy ash cleanout. The fully enclosed stainless steel wood storage area offers an easy solution for safely storing and adding your preferred solid fuel. The singular gantry system provides the clearance necessary to operate optional rotisserie attachments. Also available are three interchangeable and unique grill racks that provide versatility in grill method and needs. The Santa Maria solid fuel grill is available in 48", 60", 72", 84" sizes to fit your needs.

- Must choose size 48, 60, 72, 84

ITEM NO	
QUANTITY	
JOB NAME	
JOB NO	

PART NUMBER DESIGNATION

CP-WFG-SMG- _ - _ -

Length

Options

STANDARD FEATURES

- Stainless steel construction
- Fire brick lined fire box
- Multi level grates
- Stainless steel wood storage cabinets
- Ceramic insulation in floor and outer perimeter
- Optional exterior finishes available
- 6" Casters
- 1/2" stainless steel grates
- Two years parts and labor warranty

OPTIONS

OPTION CODE	DESCRIPTION
R	ROTISSERIE
RF	ROTISSERIE FORKS
PS	PLATE SHELF
PSC	PLATE SHELF W/CONDIMENT PAN
AC	ASH CART
WC	WOOD CART
CC	CUSTOM COLOR FINISH

CONSULTANT APPROVAL:



CHAR Products, LLC

Ph. 702-489-9888

Fax. 702-489-9898

Website: www.charprd.com

Email: info@charprd.com

2915 Losee Rd. Ste 106

N. Las Vegas, NV 89030

© copyright 2024



MODEL#	LENGTH	SHIPPING WEIGHT ESTIMATED
CP-WFG-SMG-48-__-__	48"	950 LBS.
CP-WFG-SMG-60-__-__	60"	1100 LBS.
CP-WFG-SMG-72-__-__	72"	1500 LBS.
CP-WFG-SMG-84-__-__	84"	1850 LBS.

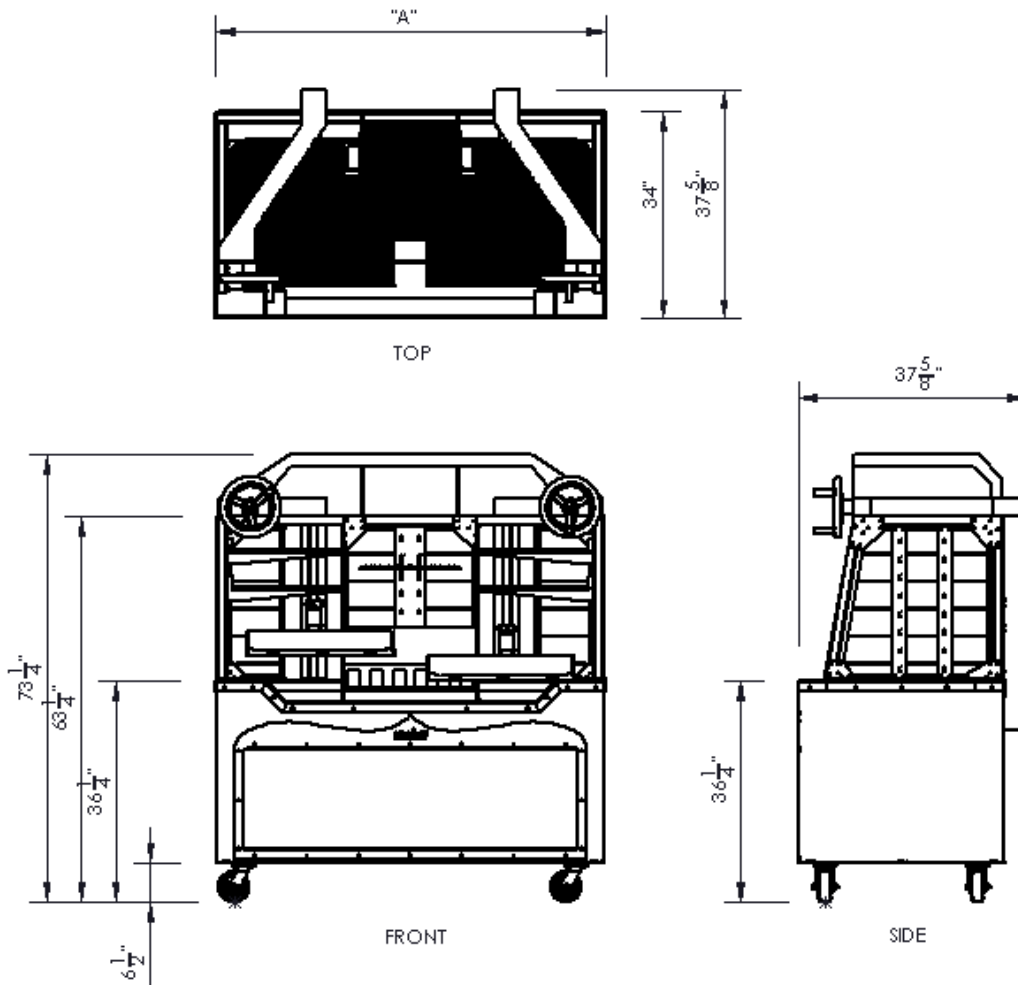

INSTALLATION INSTRUCTIONS

1. An adequate ventilation system is required for commercial use. DO NOT ATTEMPT TO OPERATE THIS EQUIPMENT WITHOUT IT.
2. Observe all local and national codes.
3. This appliance is manufactured for commercial use ONLY. It is NOT intended for residential indoor use.
4. We upgrade our products regularly and in doing so, materials, specifications, and model numbers are subject to change without notice.

CHAR Products, LLC

Ph. 702-489-9888

Website: www.charprd.com

2915 Losee Rd. Ste 106

N. Las Vegas, NV 89030