



Ignite Your Imagination



2024 CHAR PRODUCT CATALOG



## MISSION STATEMENT

**To continuously invigorate the culinary experience through research & development, innovative designs, the latest technology and creative manufacturing techniques.**

---



## VISION STATEMENT

**To bring the highest quality product on the market to our customers.**

---

**COLD****HOT****AMBIENT****RADIANT**

The core products produced are commercial appliances for the food industry.



### **About CHAR® Products, LLC.**

CHAR® is a United States based manufacturing company located in the heart of the entertainment industry: Las Vegas, Nevada. The company was founded in 2016 by the Blazvick family, a long-standing name in the culinary industry of fabrication. The Blazvick's have over 30 years of consistent, not combined, experience in commercial kitchen, design, fabrication, and service. CHAR® focuses on front of house commercial appliances that promise to give a real "WOW" factor along with a radiant experience for the customer while producing the most exciting food products available. With a full line up of products, crossing all 3 temperature zones, you can be assured that your next project will find the right, Appliances with Soul®.

Las Vegas brings a unique perspective when designing culinary equipment. The 24/7 use and nonstop operations means that products must be designed and manufactured to the highest level of standards. All CHAR® Products are just that: heavy duty engineered designs which allow extreme use daily while holding an appeal that brings the front of house alive.

3D modeling technology, state of the art fabrication techniques, and highly trained skilled craftsman allow CHAR® to bring any imaginative idea to reality. We design, engineer, and test to NSF, ETL, and/or UL standards as needed for each product and have even developed/patented several products which bring a creative appeal to the culinary world. Working closely with design consultants, our team can engineer any custom one-off product needed.

# OUR TEAM

We have the experience and talent to consult, design, and fabricate your next project. From concept to finished product, we deliver.



**Bill Blazvick**  
*President*  
bill@charprd.com



**Melissa Blazvick**  
*Managing Member*  
melissa@charprd.com



**Nathan Blazvick**  
*Vice President of Engineering and Operations*  
nate@charprd.com



**Kimberly Szumilo**  
*Office Manager/Accounting*  
kim@charprd.com



**Tadd Burns**  
*Director of Production Manager/ Technical/Resources*  
tadd@charprd.com



**Samantha Ridley**  
*Vice President of Sales*  
samantha@charprd.com



# TABLE OF CONTENTS

## **COLD PRODUCTS**.....4

- Wine Display Case
- Meat Display Case
- Equipment Base Refrigerated
- Equipment Base Freezer

## **HOT PRODUCTS**.....14

- Standard Wood Fired Grill
- Wagon Wheel Grill Solid Fuel
- Santa Maria Grill
- Robata Solid Fuel
- Churrasco Solid Fuel
- Barrel Roasting Oven
- Standard Gas Fired Grill
- Robata Gas Fuel
- Churrasco Gas Fuel
- Parilla Grill Gas Fueled Grill
- Round Broiler Non-Rotational
- Round Rotating Broiler
- Round Plancha Gas Fueled
- Tortilla Grill
- Sarj Gas Fuel
- Vertical Rotisserie

## **AMBIENT PRODUCTS**.....50

- Round Rotating Dessert Display
- Equipment Base Ambient
- Equipment Base Tube Frame

## **RADIANT PRODUCTS**.....58



## COLD

**CHAR® Products produces refrigerated equipment ranging from wine cases to dessert cases to meat aging display cases.**

---







# WINE DISPLAY CASE

## Specification Sheet



ITEM NO	
QUANTITY	
JOB NAME	
JOB NO	

### PART NUMBER DESIGNATION

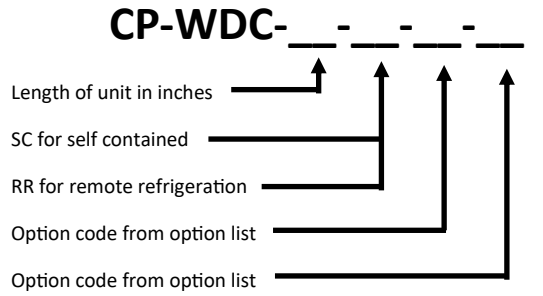

### STANDARD FEATURES

- Stainless steel interior and exterior
- Foamed in place high density CFC Free Polyurethane insulation
- 6" Legs
- Heavy duty CHAR proprietary door hinging
- Glass doors, thermal dual pane, LI glass
- Stylish full height door handles
- Door Locks
- Standard tubular wine racking
- Standard non UV- LED lighting
- Two year warranty: parts & labor

### SPECIFICATIONS

CHAR Products has over 20 years experience designing, engineering and manufacturing Wine Display cases. Our products reside all over the United States, in some of the most prestigious establishments.

Each display is custom designed to each clients specifications. Every client option request is taken and engineered into the design. Each element is evaluated for performance and conformity to ETL/NSF7/UL safety standards. Each case is tested and certified at our facility before shipment.

Contact our sales team and see what we can do for your next Wine Display case project.

- Must select Self contained (SC) or Remote Refrigeration (RR)
- Refrigerant will be R404A/R448A in all self contained units
- Consult factory for custom sizes
- Engineering collaboration with factory required on (RR) units

### OPTIONS

OPTION CODE	DESCRIPTION
WDR	CUSTOM RACKING OPTIONS
CLED	CUSTOM LED LIGHTING OPTIONS
CC	CUSTOM INTERIOR/EXTERIOR FINISH
GNG	GLASS OPTIONS
SZR	SINGLE ZONE REFRIGERATION
DZR	DUAL ZONE REFRIGERATION
MZR	MULTI ZONE REFRIGERATION

CONSULTANT APPROVAL:



<b>CHAR Products, LLC</b>	Ph. 702-489-9888	Website: <a href="http://www.charprd.com">www.charprd.com</a>	2915 Losee Rd. Ste 106
	Fax. 702-489-9898	Email: <a href="mailto:info@charprd.com">info@charprd.com</a>	N. Las Vegas, NV 89030





MODEL #	LENGTH A	ELECTRIC (SC) MODELS	SHIPPING WEIGHT ESTIMATED
CP-WDC-36-SC-__-__	36"	120V-1PH-15A	1,100 LBS
CP-WDC-48-SC-__-__	48"	120V-1PH-15A	1,250 LBS.
CP-WDC-60-SC-__-__	60"	120V-1PH-15A	1,400 LBS.
CP-WDC-72-SC-__-__	72"	120V-1PH-15A	1,550 LBS.

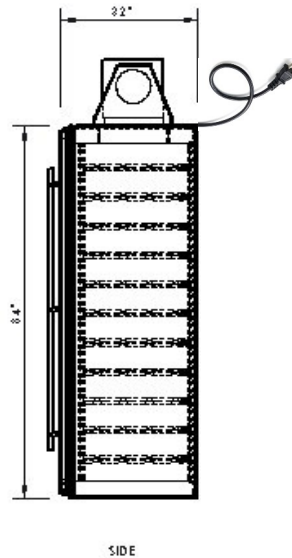
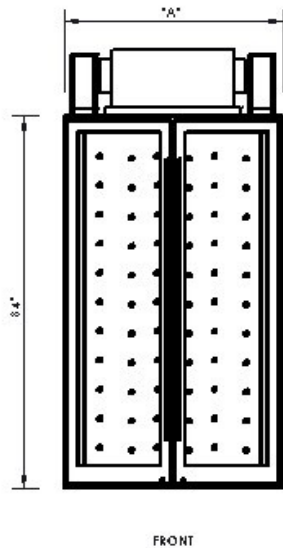
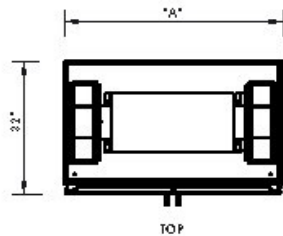

### INSTALLATION INSTRUCTIONS

1. Observe all local and national codes.
2. This appliance is manufactured for commercial use ONLY. It is NOT intended for residential indoor use.
3. We upgrade our products regularly and in doing so, materials, specifications, and model numbers are subject to change without notice.

**CHAR Products, LLC**

Ph. 702-489-9888

Fax. 702-489-9898

Website: [www.charprd.com](http://www.charprd.com)

Email: [info@charprd.com](mailto:info@charprd.com)

2915 Losee Rd. Ste 106

N. Las Vegas, NV 89030



# MEAT AGING DISPLAY CASE

## SPECIFICATION SHEET



\* Shown with optional casters

### SPECIFICATIONS

CHAR Products has over 20 years experience designing, engineering and manufacturing Meat Aging Display cases. Our products reside all over the United States, in some of the most prestigious establishments. Each element is evaluated for performance and conformity to ETL/NSF7 safety standards. Each case is tested and certified at our facility before shipment.

Contact our sales team and see what we can do for your next Meat Aging Display case project.

- Must choose (SC) for Self Contained or (RR) for Remote Refrigeration
- Consult factory for custom sizes
- Engineering collaboration with factory required on (RR) units
- Refrigerant will be R404A/R448A on all self contained units.



ITEM NO	
QUANTITY	
JOB NAME	
JOB NO	

### PART NUMBER DESIGNATION

CP-MDC- \_ - \_ - \_

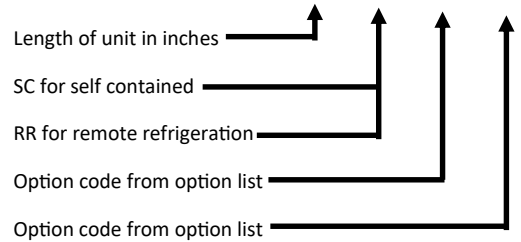

### STANDARD FEATURES

- Stainless steel interior and exterior
- Foamed in place high density Polyurethane insulation
- 6" Legs
- Humidity and temperature monitoring
- Heavy duty CHAR proprietary door hinging
- Glass doors, thermal dual pane, LI glass
- Stylish full height door handles
- Door Locks
- Standard adjustable stainless steel shelving
- Meat hooks and hanging bars
- Two year warranty: parts & labor

### OPTIONS

OPTION	DESCRIPTION
CS	CUSTOM DISPLAY SHELVING
CLED	CUSTOM LED LIGHTING OPTIONS
CC	CUSTOM INTERIOR/EXTERIOR FINISH
GNG	GLASS TINTS NON-GLARE
C	CASTERS

\*

CONSULTANT APPROVAL:

CHAR Products, LLC

Ph. 702-489-9888

Website: www.charprd.com

2915 Losee Rd. Ste 106

N. Las Vegas, NV 89030

© copyright 2024





MODEL # SELF CONTAINED	LENGTH A	ELECTRIC (SC) MODELS	SHIPPING WEIGHT ESTIMATED
CP-MDC-36-SC-__-__	36"	120V-1PH-15A	1,100 LBS
CP-MDC-48-SC-__-__	48"	120V-1PH-15A	1,250 LBS.
CP-MDC-60-SC-__-__	60"	120V-1PH-15A	1,400 LBS.
CP-MDC-72-SC-__-__	72"	120V-1PH-15A	1,550 LBS.

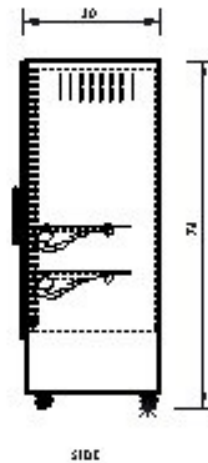
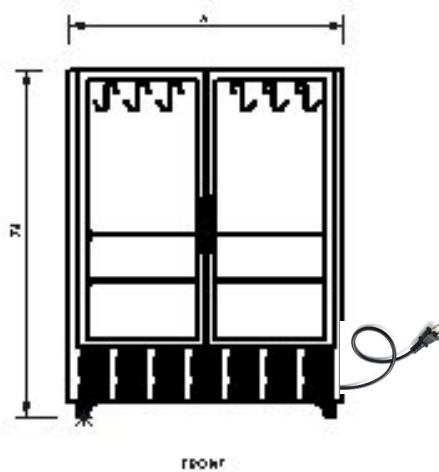
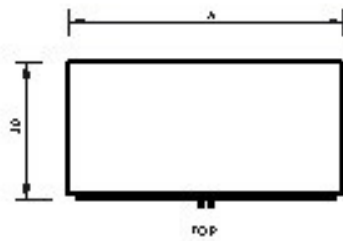

### INSTALLATION INSTRUCTIONS

1. Observe all local and national codes.
2. This appliance is manufactured for commercial use ONLY. It is NOT intended for residential indoor use.
3. We upgrade our products regularly and in doing so, materials, specifications, and model numbers are subject to change without notice.

**CHAR Products, LLC**

Ph. 702-489-9888

Fax. 702-489-9898

Website: [www.charprd.com](http://www.charprd.com)

Email: [info@charprd.com](mailto:info@charprd.com)

2915 Losee Rd. Ste 106

N. Las Vegas, NV 89030



# EQUIPMENT BASE REFRIGERATED

## SPECIFICATION SHEET

ITEM NO	
QUANTITY	
JOB NAME	
JOB NO	



\*SHOWN WITH OPTIONAL CASTERS

### SPECIFICATIONS

CHAR Products has over 20 years experience designing, engineering and manufacturing Freezer Equipment Bases. Our products reside all over the United States, in some of the most prestigious establishments.

Contact our sales team and see what we can do for your next Freezer Equipment Base project.

- Must select length 36",48",60"72"
- Must select refrigeration type (SC) self contained (RR) remote refrigeration
- Self contained will be R404A/R448A refrigerant standard

### PART NUMBER DESIGNATION

**CP-EBR-** - - -

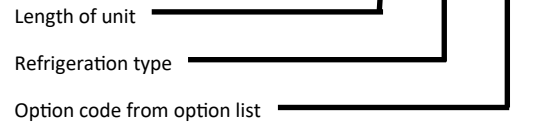

### STANDARD FEATURES

- Stainless steel interior and exterior
- Foamed in place high density CFC Free Polyurethane insulation
- Heavy duty 6" adjustable legs
- Digital temperature control
- Doors or drawers include full perimeter magnetic gaskets
- Stainless steel adjustable wire shelf included with door models
- Full extension slide assemblies included with drawer models
- Solid sub top
- Two year warranty parts and labor
- Five year warranty compressor

### OPTIONS

OPTION	DESCRIPTION
C	FOUR 6" ROLLING CASTERS TWO LOCKING
DR	DOORS
DRW	DRAWERS
FCI	FIBER CERAMIC INSULATE TOP

\*

CONSULTANT APPROVAL:



**CHAR Products, LLC**

Ph. 702-489-9888

Fax. 702-489-9898

Website: [www.charprd.com](http://www.charprd.com)

Email: [info@charprd.com](mailto:info@charprd.com)

2915 Losee Rd. Ste 106

N. Las Vegas, NV 89030

© copyright 2024



MODEL #	LENGTH A	ELECTRIC	BTU H	SHIPPING WEIGHT ESTIMATED
CP-EBR-36-__-__-__	36"	120V-1PH-10A	1100	350 LBS.
CP-EBR-48-__-__-__	48"	120V-1PH-10A	1300	375 LBS.
CP-EBR-60-__-__-__	60"	120V-1PH-10A	1500	400 LBS.
CP-EBR-72-__-__-__	72"	120V-1PH-10A	1700	450 LBS.

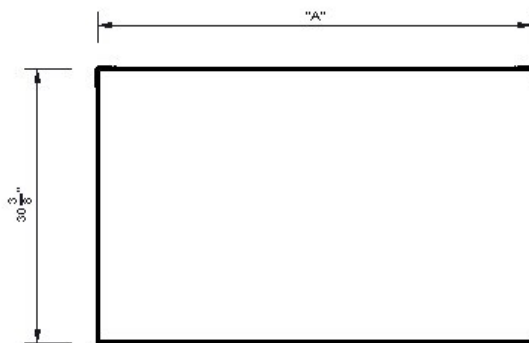

TOP

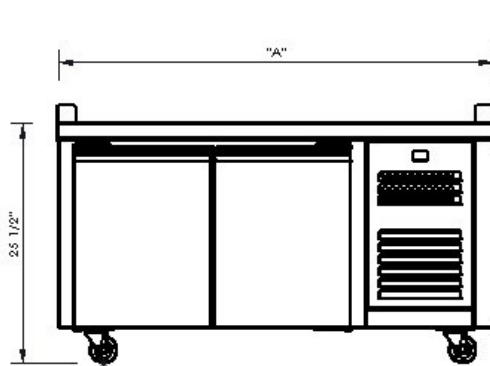

FRONT

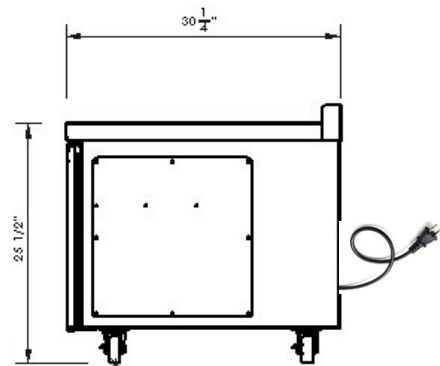

SIDE

### INSTALLATION INSTRUCTIONS

1. Observe all local and national codes.
2. This appliance is manufactured for commercial use ONLY. It is NOT intended for residential indoor use.
3. We upgrade our products regularly and in doing so, materials, specifications, and model numbers are subject to change without notice.

**CHAR Products, LLC**

Ph. 702-489-9888

Fax. 702-489-9898

Website: [www.charprd.com](http://www.charprd.com)

Email: [info@charprd.com](mailto:info@charprd.com)

2915 Losee Rd. Ste 106

N. Las Vegas, NV 89030



# EQUIPMENT BASE FREEZER

## SPECIFICATION SHEET

ITEM NO	
QUANTITY	
JOB NAME	
JOB NO	

### PART NUMBER DESIGNATION

**CP-EBF-** - -

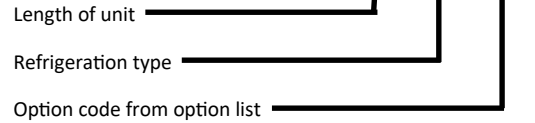

\* SHOWN WITH OPTIONAL CASTERS

### STANDARD FEATURES

- Stainless steel interior and exterior
- Foamed in place high density CFC Free Polyurethane insulation
- Heavy duty 6" adjustable legs
- Digital temperature control
- Doors or drawers include full perimeter magnetic gaskets
- Stainless steel adjustable wire shelf included with door models
- Full extension slide assemblies included with drawer models
- Solid sub top
- Two year warranty parts and labor
- Five year warranty compressor

### OPTIONS

OPTION CODE	DESCRIPTION
C	FOUR 6" ROLLING CASTERS TWO LOCKING
DR	DOORS
DRW	DRAWERS
FCI	FIBER CERAMIC

### SPECIFICATIONS

CHAR Products has over 20 years experience designing, engineering and manufacturing Freezer Equipment Bases. Our products reside all over the United States, in some of the most prestigious establishments.

Contact our sales team and see what we can do for your next Freezer Equipment Base project.

- Must select length 36", 48", 60", 72"
- Must choose (SC) for self contained or (RR) for remote refrigeration
- Self contained will be R404A/R448a refrigerant standard



CONSULTANT APPROVAL:

---

**CHAR Products, LLC**

Ph. 702-489-9888

Fax. 702-489-9898

Website: [www.charprd.com](http://www.charprd.com)

Email: [info@charprd.com](mailto:info@charprd.com)

2915 Losee Rd. Ste 106

N. Las Vegas, NV 89030





MODEL #	LENGTH	ELECTRIC	BTU H	SHIPPING WEIGHT
CP-EBF-36-__-__	36"	120V-1PH-10A	1100	300 LBS.
CP-EBF-48-__-__	48"	120V-1PH-10A	1300	325 LBS.
CP-EBF-60-__-__	60"	120V-1PH-10A	1500	350 LBS.
CP-EBF-72-__-__	72"	120V-1PH-10A	1700	400 LBS.

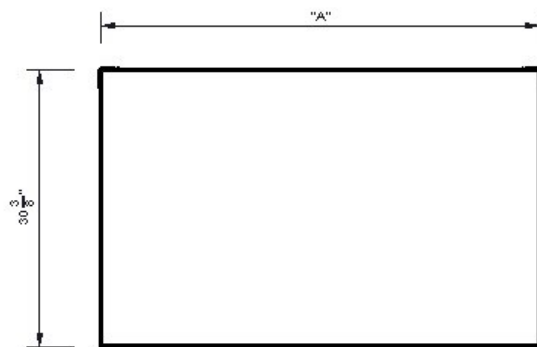

TOP

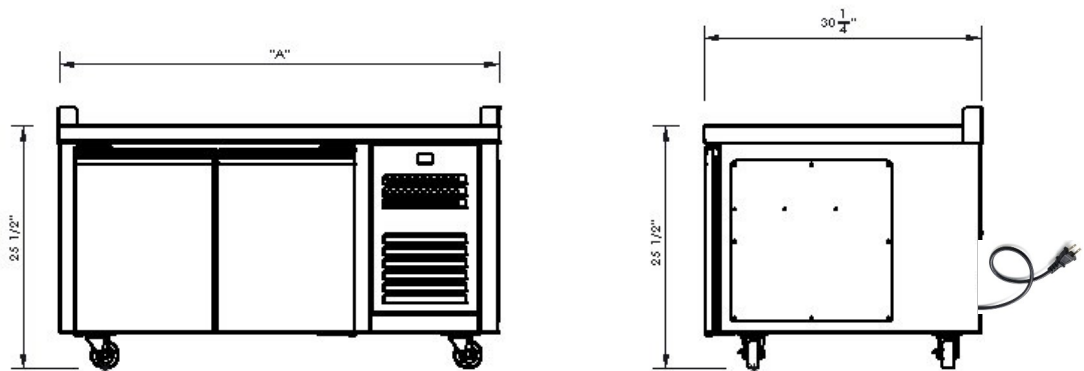

FRONT

SIDE

### INSTALLATION INSTRUCTIONS

1. Observe all local and national codes.
2. This appliance is manufactured for commercial use ONLY. It is NOT intended for residential indoor use.
3. We upgrade our products regularly and in doing so, materials, specifications, and model numbers are subject to change without notice.

**CHAR Products, LLC**

Ph. 702-489-9888

Fax. 702-489-9898

Website: [www.charprd.com](http://www.charprd.com)

Email: [info@charprd.com](mailto:info@charprd.com)

2915 Losee Rd. Ste 106

N. Las Vegas, NV 89030

# HOT

**CHAR® Products can produce a wide range of cooking appliances: Exhibition cooking, Wood-Fired cooking and Gas Fired cooking appliances**









# STANDARD WOOD FIRED GRILL

## SPECIFICATION SHEET



ITEM NO	
QUANTITY	
JOB NAME	
JOB NO	

### PART NUMBER DESIGNATION

**CP-WFG-STD-** - - -



### STANDARD FEATURES

- 1/4' steel body
- Ceramic cloth insulated body
- Ceramic Brick lined fire box
- 6" casters two locking
- Skewers included
- 1/2" thick laser cut removable steel grates
- Cleaning kit
- Two year warranty parts and labor

### OPTIONS

OPTION CODE	DESCRIPTION
RRG	ROUND ROD GRATES
PS	PLATE SHELF
PSC	PLATE SHELF W/CONDIMENT INSERTS
CC	CUSTOM COLOR FINISH

### SPECIFICATIONS

The solid fueled CHAR Standard Grill is available in single tier configurations in four different sizes. To ensure performance and longevity these units are constructed entirely 1/4" steel and have a ceramic cloth exterior, and a ceramic brick lined fire box

- Must select length 36", 48", 60", 72"

CONSULTANT APPROVAL:

---



**CHAR Products, LLC** Ph. 702-489-9888 Website: [www.charprd.com](http://www.charprd.com) 2915 Losee Rd. Ste 106  
 Fax. 702-489-9898 Email: [info@charprd.com](mailto:info@charprd.com) N. Las Vegas, NV 89030



MODEL #	LENGTH A	SHIPPING WEIGHT ESTIMATED
CP-WFG-STD-36-__-__	36"	656 LBS.
CP-WFG-STD-48-__-__	48"	874 LBS.
CP-WFG-STD-60-__-__	60"	1,093 LBS.
CP-WFG-STD-72-__-__	72"	1,311 LBS.

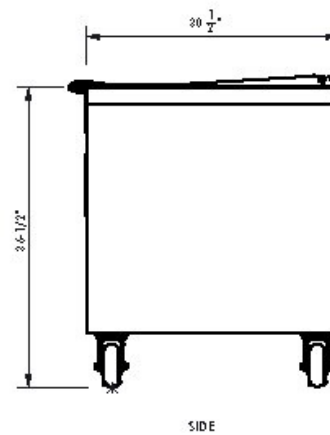
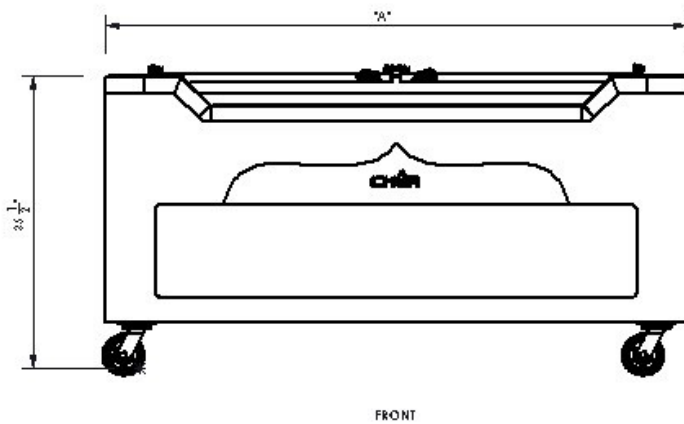
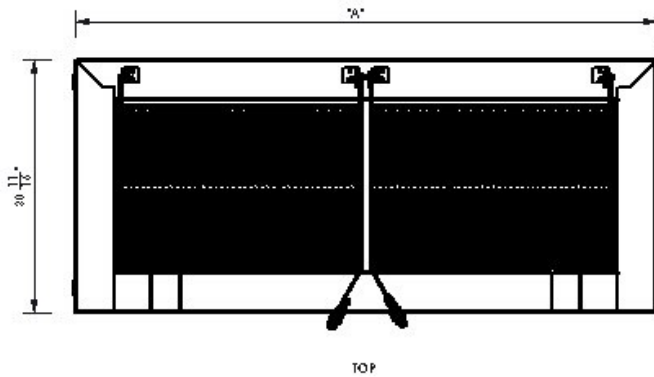

### INSTALLATION INSTRUCTIONS

1. An adequate ventilation system is required for commercial use. DO NOT ATTEMPT TO OPERATE THIS EQUIPMENT WITHOUT IT.
2. Observe all local and national codes.
3. This appliance is manufactured for commercial use ONLY. It is NOT intended for residential indoor use.
4. We upgrade our products regularly and in doing so, materials, specifications, and model numbers are subject to change without notice.

**CHAR Products, LLC**

Ph. 702-489-9888  
Fax. 702-489-9898

Website: [www.charprd.com](http://www.charprd.com)  
Email: [info@charprd.com](mailto:info@charprd.com)

2915 Lose Rd. Ste 106  
N. Las Vegas, NV 89030



# WAGON WHEEL GRILL SOLID FUEL

## SPECIFICATION SHEET

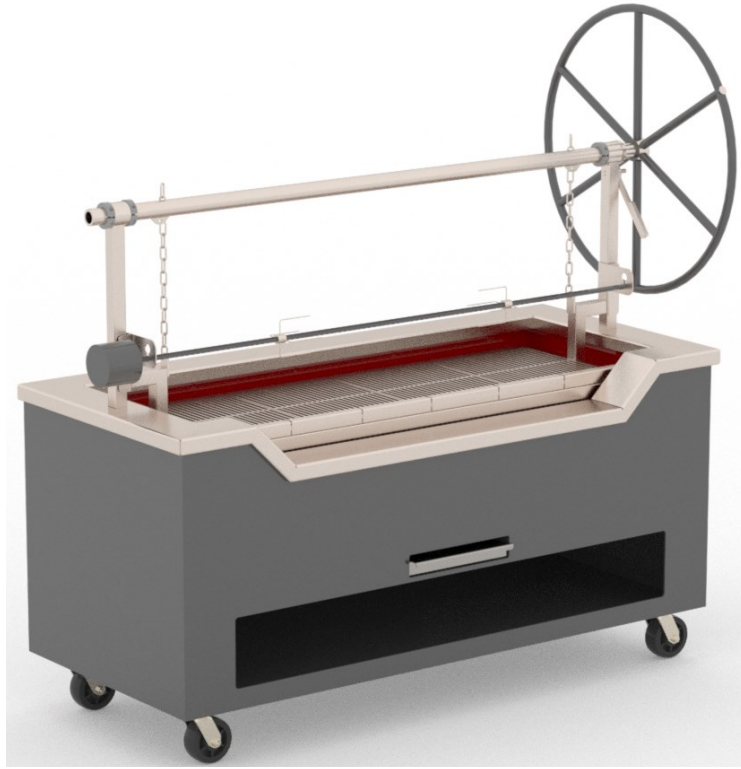

\* SHOWN WITH OPTIONAL ROTISSERIE

### SPECIFICATIONS

The CHAR Wagon Wheel Grill has a wheel crank to raise and lower the grill grates. Currently available in 48", 60", 72" and 84". The Wagon Wheel Grill has an insulated exterior and a fire brick lined fire box. The unit has removable grilling grates, with options for laser cut stainless steel "V" style, round rod style, or flat style griddle plates. The lower section is for wood storage. The base model has a beautiful satin black powder coat finish. However optional colors including stainless steel are available.

ITEM NO	
QUANTITY	
JOB NAME	
JOB NO	

### PART NUMBER DESIGNATION

CP-WFG-WWG- \_ - \_

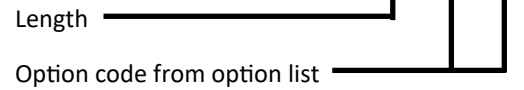

### STANDARD FEATURES

- 1/4" thick powder coated steel body
- Ceramic insulated exterior surface
- 1/4" steel fire box
- Fire brick lined
- 3/8" thick laser cut removable steel grates
- Heavy duty 6" swivel casters (two locking)
- Two year warranty parts and labor

### OPTIONS

OPTION CODE	DESCRIPTION
AL	6" ADJUSTABLE LEGS
GP	3/8" POLISHED GRIDDLE PLATE
SSG	STAINLESS STEEL LASER CUT GRATES
VG	V-STYLE GRATES
RRG	ROUND ROD GRATES
* RS	ROTISSERIE W/SKEWER
PCO	PAN CUT-OUTS
PS	PLATE SHELF
AC	ASH CART
WA	WOOD CART
CC	CUSTOM COLOR FINISH

CONSULTANT APPROVAL:

\_\_\_\_\_



CHAR Products, LLC

Ph. 702-489-9888

Fax. 702-489-9898

Website: www.charprd.com

Email: info@charprd.com

2915 Losee Rd. Ste 106

N. Las Vegas, NV 89030

© copyright 2024





MODEL #	LENGTH A	ESTIMATED SHIPPING WEIGHT
CP-WFG-WWG-48-__-__	48"	950 LBS.
CP-WFG-WWG-60-__-__	60"	1100 LBS.
CP-WFG-WWG-72-__-__	72"	1500 LBS.
CP-WFG-WWG-84-__-__	84"	1850 LBS.

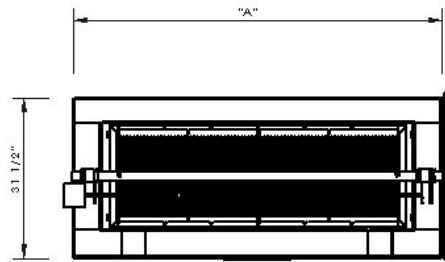

TOP

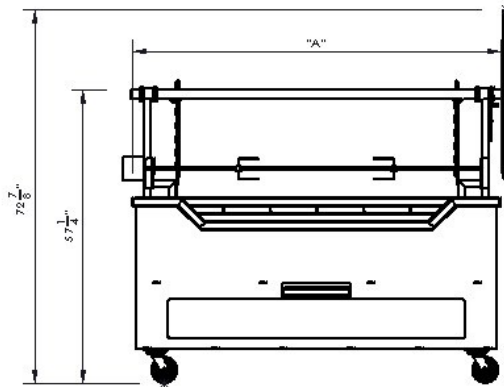

FRONT

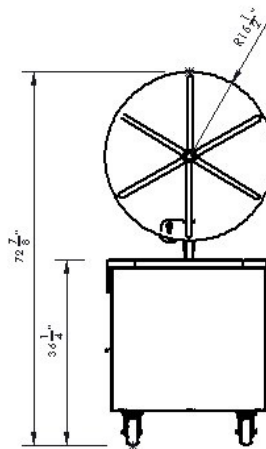

SIDE

### INSTALLATION INSTRUCTIONS

1. An adequate ventilation system is required for commercial use. DO NOT ATTEMPT TO OPERATE THIS EQUIPMENT WITHOUT IT.
2. Observe all local and national codes.
3. This appliance is manufactured for commercial use ONLY. It is NOT intended for residential indoor use.
4. We upgrade our products regularly and in doing so, materials, specifications, and model numbers are subject to change without notice.

**CHAR Products, LLC**

Ph. 702-489-9888

Fax. 702-489-9898

Website: [www.charprd.com](http://www.charprd.com)

Email: [info@charprd.com](mailto:info@charprd.com)

2915 Losee Rd. Ste 106

N. Las Vegas, NV 89030



# SANTA MARIA SOLID FUEL GRILL

## SPECIFICATION SHEET



### SPECIFICATIONS

The CHAR solid fuel Santa Maria Grill is manufactured to precise standards using 304 stainless steel full body construction and heavy duty support frame. Operator safety and comfort is strengthened through the use of ceramic lined exterior panels that prevent heat transfer. Enhanced cooking performance is achieved through the use of refractory brick lined burn pit with tailgate style access for easy ash cleanout. The fully enclosed stainless steel wood storage area offers an easy solution for safely storing and adding your preferred solid fuel. The singular gantry system provides the clearance necessary to operate optional rotisserie attachments. Also available are three interchangeable and unique grill racks that provide versatility in grill method and needs. The Santa Maria solid fuel grill is available in 48", 60", 72", 84" sizes to fit your needs.

- Must choose size 48, 60, 72, 84

ITEM NO	
QUANTITY	
JOB NAME	
JOB NO	

### PART NUMBER DESIGNATION

**CP-WFG-SMG-**

Length

Options

### STANDARD FEATURES

- Stainless steel construction
- Fire brick lined fire box
- Multi level grates
- Stainless steel wood storage cabinets
- Ceramic insulation In floor and outer perimeter
- Optional exterior finishes available
- 6" Casters
- Two years parts and labor warranty

### OPTIONS

OPTION CODE	DESCRIPTION
R	ROTISSERIE
VGG	V-SHAPE GRILL GRATE
GP	GRIDDLE PLATE
PS	PLATE SHELF
PSC	PLATE SHELF W/ CONDIMENT PAN
CM	CURB MOUNTED
CC	POWDERCOAT CUSTOM COLOR

CONSULTANT APPROVAL:



**CHAR Products, LLC**

Ph. 702-489-9888

Fax. 702-489-9898

Website: [www.charprd.com](http://www.charprd.com)

Email: [info@charprd.com](mailto:info@charprd.com)

2915 Losee Rd. Ste 106

N. Las Vegas, NV 89030

© copyright 2024



MODEL#	LENGTH	SHIPPING WEIGHT ESTIMATED
CP-WFG-SMG-48-__-__	48"	950 LBS.
CP-WFG-SMG-60-__-__	60"	1100 LBS.
CP-WFG-SMG-72-__-__	72"	1500 LBS.
CP-WFG-SMG-84-__-__	84"	1850 LBS.

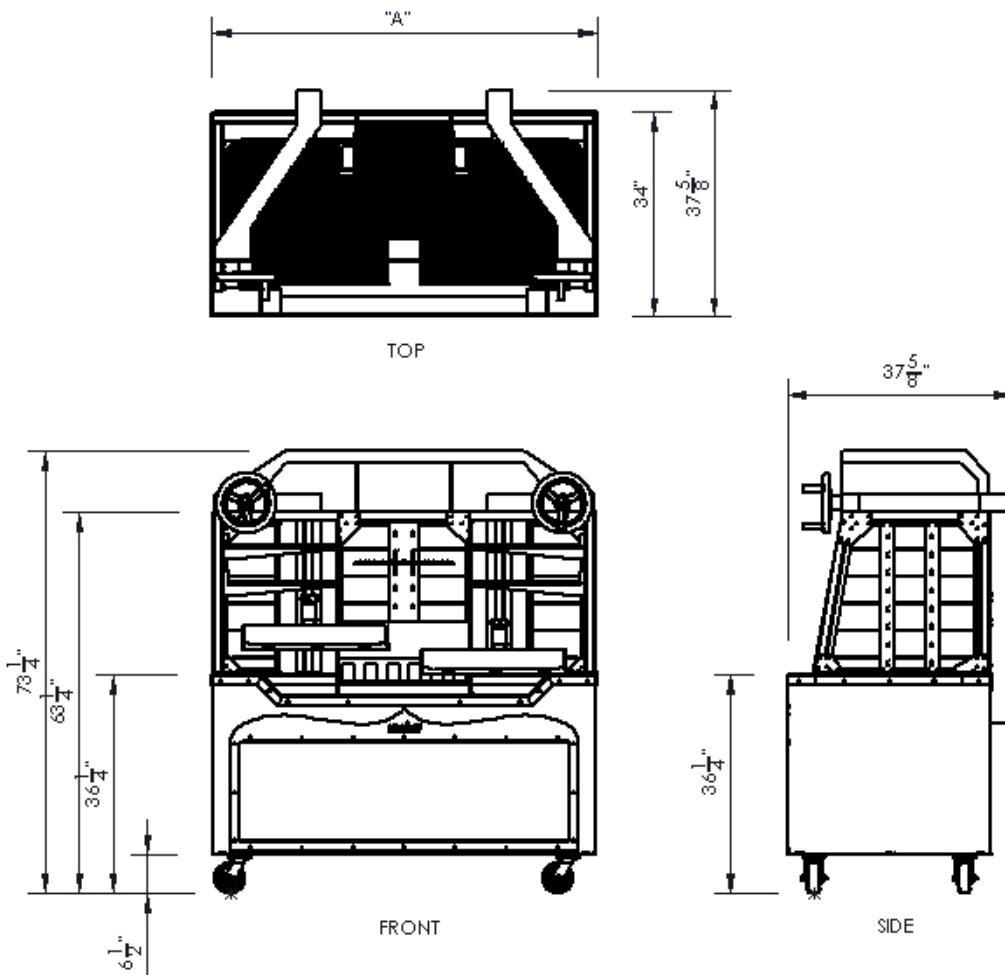

### INSTALLATION INSTRUCTIONS

1. An adequate ventilation system is required for commercial use. DO NOT ATTEMPT TO OPERATE THIS EQUIPMENT WITHOUT IT.
2. Observe all local and national codes.
3. This appliance is manufactured for commercial use ONLY. It is NOT intended for residential indoor use.
4. We upgrade our products regularly and in doing so, materials, specifications, and model numbers are subject to change without notice.

**CHAR Products, LLC**

Ph. 702-489-9888

Fax. 702-489-9898

Website: [www.charprd.com](http://www.charprd.com)

Email: [info@charprd.com](mailto:info@charprd.com)

2915 Losee Rd. Ste 106

N. Las Vegas, NV 89030





# ROBATA SOLID FUEL

## SPECIFICATION SHEET



ITEM NO	
QUANTITY	
JOB NAME	
JOB NO	

### PART NUMBER DESIGNATION

**CP-WFG-ROB-** - - -

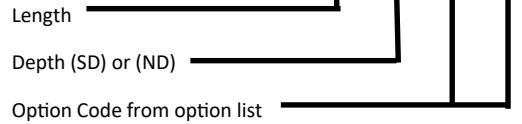

### STANDARD FEATURES

- 14 gauge stainless steel body
- Ceramic cloth insulated exterior
- Fully welded 14 gauge stainless fire box
- Fire brick lined
- 1/2" thick laser cut removable.
- Adjustable Skewer Bars
- Adjustable leveling feet
- Grill cleaning kit
- Two year warranty parts and labor
- Grill cleaning kit

### OPTIONS

OPTION CODE	DESCRIPTION
OHWR1	OVERHEAD WARMING RACK 1 TIER
OHWR2	OVERHEAD WARMING RACK 2 TIER
SSG	1/2" THICK STAINLESS STEEL GRATE
GP	1/2" THICK STAINLESS STEEL

### SPECIFICATIONS

This CHAR Robata Grill is solid fueled and constructed of 304 stainless steel. Currently available in 36", 48", 60" and 72" lengths Units have ceramic insulated exteriors. The quality of this grill will ensure performance and longevity. Standard 3" adjustable leveling feet.

- Must select (SD) (28.5") for Standard Depth or (ND) (20") for Narrow Depth
- Must select 36", 48", 60", 72" in length for part number
- See Equipment base spec sheets separately

CONSULTANT APPROVAL:

---



CHAR Products, LLC

Ph. 702-489-9888

Website: www.charprd.com

2915 Losee Rd. Ste 106

N. Las Vegas, NV 89030



MODEL #	LENGTH A	NARROW DEPTH	STANDARD DEPTH	SHIPPING WEIGHT
CP-WFG-ROB-36-__-__	36"	20"	28.5"	150 LBS.
CP-WFG-ROB-48-__-__	48"	20"	28.5"	200 LBS.
CP-WFG-ROB-60-__-__	60"	20"	28.5"	250 LBS.
CP-WFG-ROB-72-__-__	72"	20"	28.5"	300 LBS.

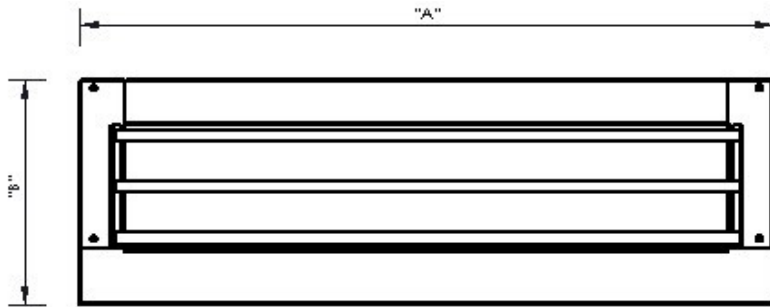

TOP

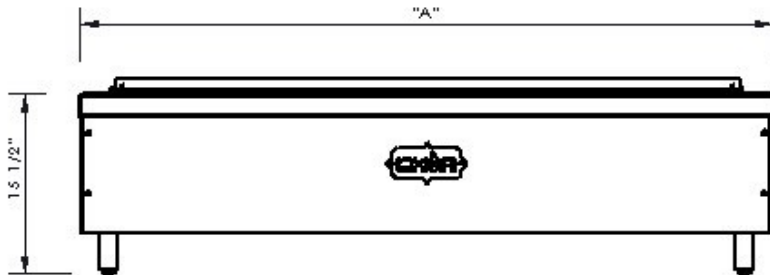

FRONT

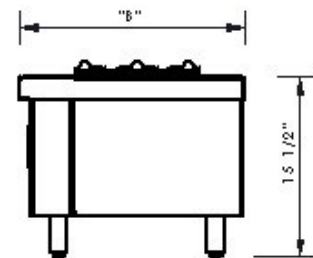

SIDE

### INSTALLATION INSTRUCTIONS

1. An adequate ventilation system is required for commercial use. DO NOT ATTEMPT TO OPERATE THIS EQUIPMENT WITHOUT IT.
2. Observe all local and national codes.
3. Proper combustion requires this unit to remain on 3" legs
4. This appliance is manufactured for commercial use ONLY. It is NOT intended for residential indoor use.
5. We upgrade our products regularly and in doing so, materials, specifications, and model numbers are subject to change without notice.

**CHAR Products, LLC**

Ph. 702-489-9888

Fax. 702-489-9898

Website: [www.charprd.com](http://www.charprd.com)

Email: [info@charprd.com](mailto:info@charprd.com)

2915 Lose Rd. Ste 106

N. Las Vegas, NV 89030



# CHURRASCO SOLID FUEL

## SPECIFICATION SHEET



ITEM NO	
QUANTITY	
JOB NAME	
JOB NO	

### PART NUMBER DESIGNATION

CP-WFG-CHU- - -

Length

Option code from option list

### STANDARD FEATURES

- 14 gauge stainless steel body
- Ceramic cloth insulated body
- Overhead resting rack
- Fully welded 14 gauge stainless fire box
- Ceramic Brick lined fire box
- Adjustable leveling feet
- Skewers included
- 1/2" thick laser cut removable steel grates
- Cleaning kit
- Two year warranty parts and labor

### OPTIONS

OPTION	DESCRIPTION
RPS	REMOVABLE 8" PLATE SHELF
SG	STAINLESS STEEL GRATE
FG	FISH GRATES
PSC	PLATE SHELF 1/6 PAN CONDIMENT INSERTS

### SPECIFICATIONS

The solid fueled CHAR Churrasco Broiler is available in single tier configurations in four different sizes. Each comes with rotating spits. A proven industrial gear motor offers years of uninterrupted operation of the rotating spits. To ensure performance and longevity these units are constructed entirely of 304 stainless steel and have a ceramic cloth exterior, and a ceramic brick lined fire box

- Must select length 36", 48", 60", 72"
- See spec sheets for cabinet and table bases



CONSULTANT APPROVAL:

CHAR Products, LLC

Ph. 702-489-9888  
Fax. 702-489-9898

Website: www.charprd.com  
Email: info@charprd.com

2915 Losee Rd. Ste 106  
N. Las Vegas, NV 89030



MODEL #	LENGTH A	SHIPPING WEIGHT ESTIMATED
CP-WFG-CHU-36-__-__	36"	656 LBS.
CP-WFG-CHU-48-__-__	48"	874 LBS.
CP-WFG-CHU-60-__-__	60"	1,093 LBS.
CP-WFG-CHU-72-__-__	72"	1,311 LBS.

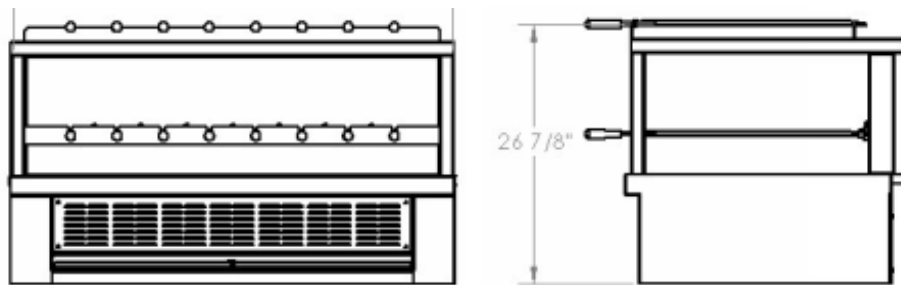
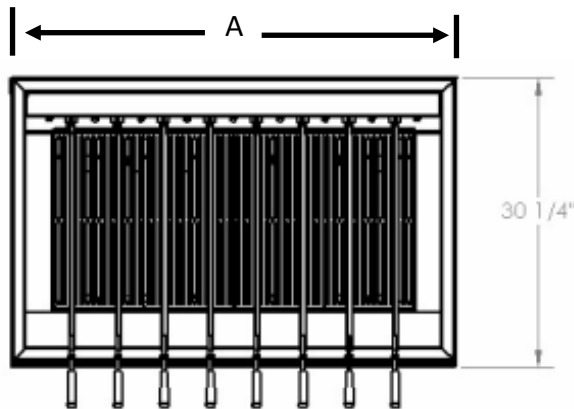

### INSTALLATION INSTRUCTIONS

1. An adequate ventilation system is required for commercial use. DO NOT ATTEMPT TO OPERATE THIS EQUIPMENT WITHOUT IT.
2. Observe all local and national codes.
3. Proper combustion requires this unit to remain on 3" legs
4. This appliance is manufactured for commercial use ONLY. It is NOT intended for residential indoor use.
5. We upgrade our products regularly and in doing so, materials, specifications, and model numbers are subject to change without notice.

**CHAR Products, LLC**

Ph. 702-489-9888

Fax. 702-489-9898

Website: [www.charprd.com](http://www.charprd.com)

Email: [info@charprd.com](mailto:info@charprd.com)

2915 Lose Rd. Ste 106

N. Las Vegas, NV 89030





# BARREL ROASTING OVEN

## SPECIFICATION SHEET



ITEM NO	
QUANTITY	
JOB NAME	
JOB NO	

### PART NUMBER DESIGNATION

# CP-WFG-BRO

### STANDARD FEATURES

- Heavy duty stainless steel components
- Cast ceramic oven chamber and fire box
- Fully welded stainless steel fire box enclosure
- Heavy duty base frame
- Removable cooking grate and oven lid
- Grease drain (grease trap to be provided by others)
- Two year warranty, parts and labor

### SPECIFICATIONS

The CHAR Barrel Roasting Oven is a solid fuel, cast ceramic oven. The ceramic vessel insulates the exterior from extreme temperatures, while maintaining an ideal cooking temperature. The top opening of the ceramic cooking chamber is 25.72" opening. This allows access for hanging or grilling food items. The outside of this chamber is insulated and covered with an expanded metal mesh which functions as an attachment point for a stucco or tile finish (to be provided by others). The unit is mounted on a heavy duty frame designed for forklift mobility and ease of installation.

CONSULTANT APPROVAL:

---



**CHAR Products, LLC**

Ph. 702-489-9888

Fax. 702-489-9898

Website: [www.charprd.com](http://www.charprd.com)

Email: [info@charprd.com](mailto:info@charprd.com)

2915 Losee Rd. Ste 106

N. Las Vegas, NV 89030



MODEL #	LENGTH	WIDTH	SHIPPING WEIGHT ESTIMATED
CP-WFG-BRO	70 15/16"	38"	2200 LBS.

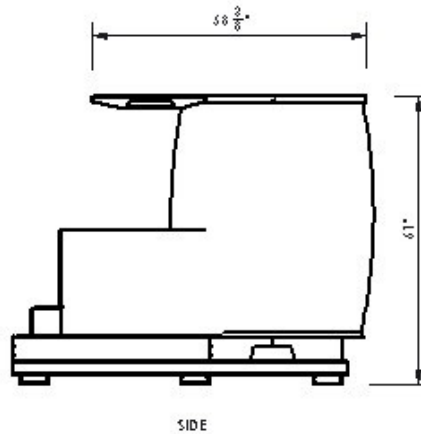
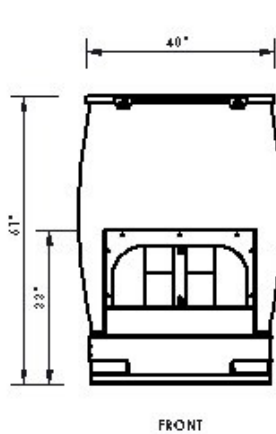
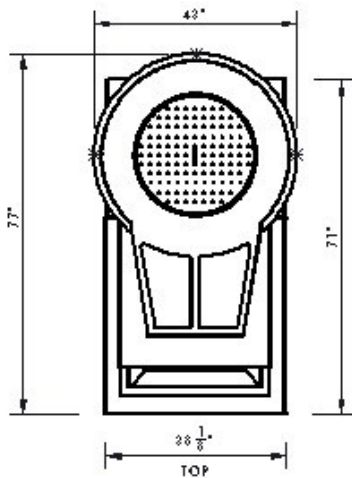

### INSTALLATION INSTRUCTIONS

1. An adequate ventilation system is required for commercial use. DO NOT ATTEMPT TO OPERATE THIS EQUIPMENT WITHOUT IT.
2. Observe all local and national codes.
3. This appliance is manufactured for commercial use ONLY. It is NOT intended for residential indoor use.
4. We upgrade our products regularly and in doing so, materials, specifications, and model numbers are subject to change without notice.

**CHAR Products, LLC**

Ph. 702-489-9888

Fax. 702-489-9898

Website: [www.charprd.com](http://www.charprd.com)

Email: [info@charprd.com](mailto:info@charprd.com)

2915 Losee Rd. Ste 106

N. Las Vegas, NV 89030



# STANDARD GAS FIRED GRILL

## SPECIFICATION SHEET



### SPECIFICATIONS

The Gas Fueled CHAR Standard Grill is available in in four different sizes. To ensure performance and longevity these units are constructed entirely of 14 gauge stainless steel and have a ceramic cloth insulated body.

- Must select length 36", 48", 60", 72"
- Must select gas type (LP) for Propane (NG) for Natural Gas

ITEM NO	
QUANTITY	
JOB NAME	
JOB NO	

### PART NUMBER DESIGNATION

**CP-GFG-STD-** - - -

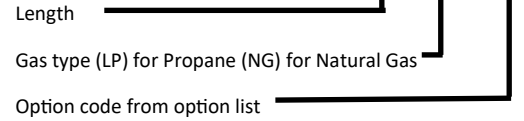

### STANDARD FEATURES

- 14 gauge stainless steel body
- Ceramic cloth insulated body
- Multiple gas control valves for precise heat control
- Adjustable leveling feet
- Removable drip pan
- 1/2" thick laser cut removable steel grates
- 3/4" gas connection
- Cleaning kit
- Appropriate gas regulator (for gas type selected)
- Two year warranty parts and labor

### OPTIONS

OPTION CODE	DESCRIPTION
FQD	48" FLEX QUICK DISCONNECT
OHWR1	OVERHEAD WARMING RACK 1 TIER
OHWR2	OVERHEAD WARMING RACK 2 TIER
GP	1/2" STAINLESS STEEL POLISHED GRIDDLE PLATE
SSG	1/2" STAINLESS STEEL GRATE
R	ROTISSERIE
RF	ROTISSERIE FORKS
PS	PLATE SHELF
PSC	PLATE SHELF W/CONDIMENT INSERTS
FF	FEATURE FLAME

CONSULTANT APPROVAL:

---



**CHAR Products, LLC**

Ph. 702-489-9888

Fax. 702-489-9898

Website: [www.charprd.com](http://www.charprd.com)

Email: [info@charprd.com](mailto:info@charprd.com)

2915 Losee Rd. Ste 106

N. Las Vegas, NV 89030



MODEL #	LENGTH A	FUEL LINE SIZE	BTU INPUT NG	SHIPPING WEIGHT ESTIMATED
CP-GFG-STD-36-__-__	36"	3/4"	66,000	656 LBS.
CP-GFG-STD-48-__-__	48"	3/4"	115,500	874 LBS.
CP-GFG-STD-60-__-__	60"	3/4"	148,500	1,093 LBS.
CP-GFG-STD-72-__-__	72"	3/4"	165,000	1,311 LBS.

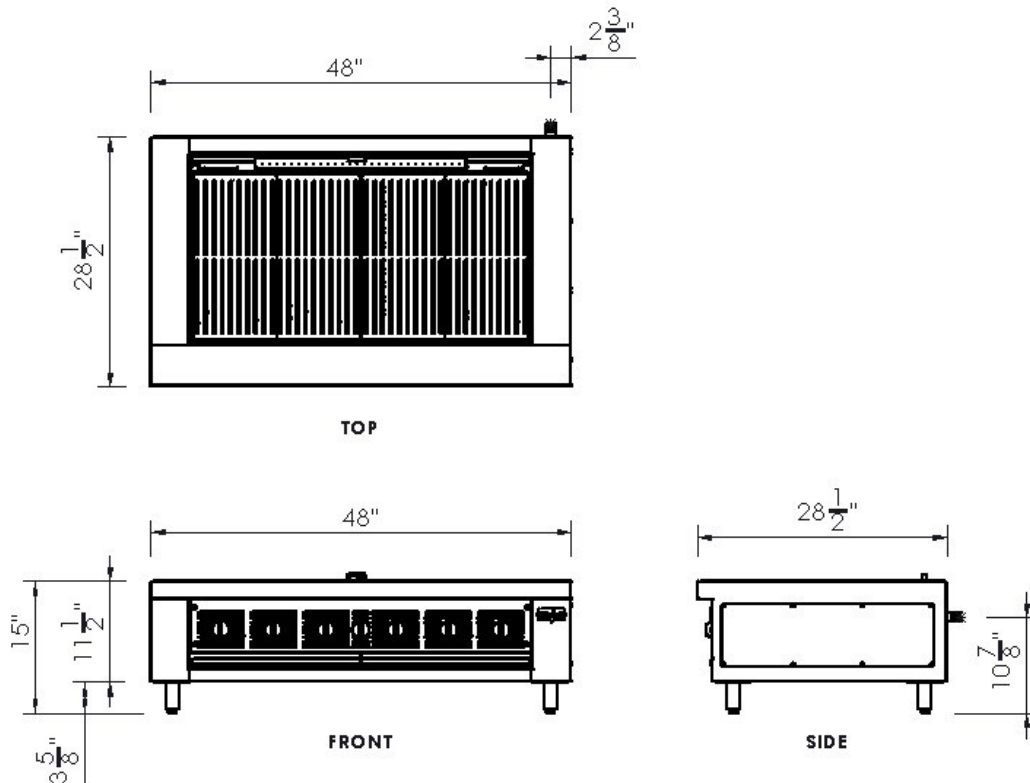

### INSTALLATION INSTRUCTIONS

1. A properly sized gas line must be provided. All units are internally regulated. DO NOT DUAL REGULATE.
2. An adequate ventilation system is required for commercial use. DO NOT ATTEMPT TO OPERATE THIS EQUIPMENT WITHOUT IT.
3. Observe all local and national codes.
4. Proper combustion requires this unit to remain on 3" legs.
5. This appliance is manufactured for commercial use ONLY. It is NOT intended for residential indoor use.
6. We upgrade our products regularly and in doing so, materials, specifications, and model numbers are subject to change without notice.

**CHAR Products, LLC**

Ph. 702-489-9888

Fax. 702-489-9898

Website: [www.charprd.com](http://www.charprd.com)

Email: [info@charprd.com](mailto:info@charprd.com)

2915 Losee Rd. Ste 106

N. Las Vegas, NV 89030





# ROBATA GAS FUEL

## SPECIFICATION SHEET

ITEM NO	
QUANTITY	
JOB NAME	
JOB NO	

### PART NUMBER DESIGNATION

**CP-GFG-ROB-** - - - -

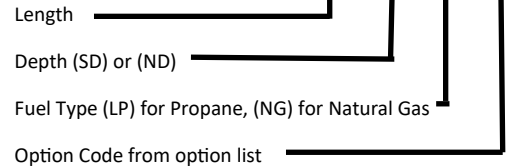

### STANDARD FEATURES

- 14 gauge stainless steel body
- Multiple gas control valves for precise heat control
- Fully welded 14 gauge stainless fire box
- Stainless lined
- 1/2" thick laser cut removable grill grates
- Adjustable Skewer Bars
- Adjustable leveling feet
- Removable stainless burners
- Cleaning kit
- Two year warranty parts and labor

OPTIONS	
OPTION CODE	DESCRIPTION
FQD	48" FLEX QUICK DISCONNECT
OHWR1	OVERHEAD WARMING RACK 1 TIER
OHWR2	OVERHEAD WARMING RACK 2 TIER
GP	1/2" POLISHED STAINLESS STEEL GRIDDLE PLATE
SSG	1/2" STAINLESS STEEL GRATE
PS	PLATE SHELF
PSC	PLATE SHELF 1/6 PAN CONDIMENT INSERTS
FF	FEATURE FLAME

CONSULTANT APPROVAL:

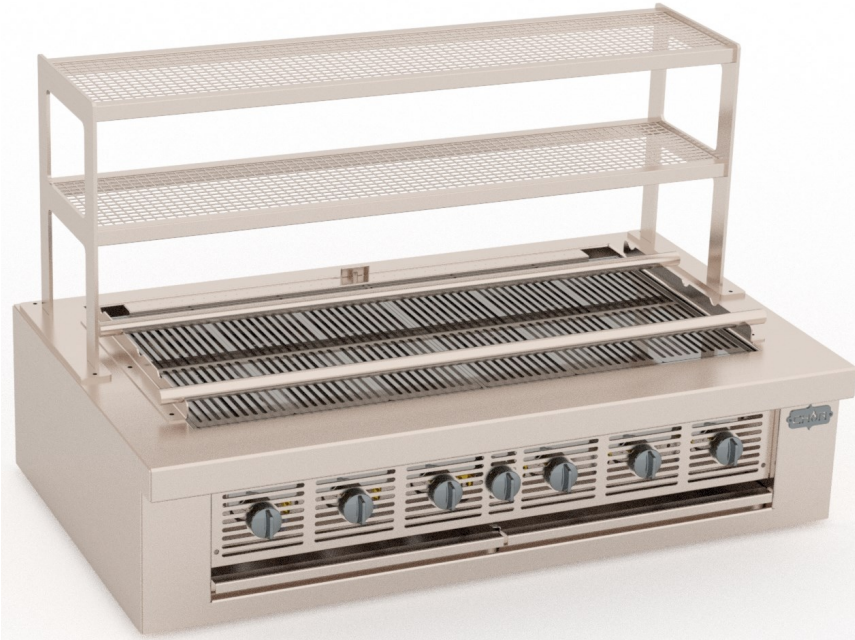

### SPECIFICATIONS

This CHAR Robata Grill is GAS fueled and constructed of 304 stainless steel. Currently available in 36", 48", 60" and 72" lengths Units have ceramic insulated exteriors and heavy duty stainless steel burners. The quality of this grill will ensure performance and longevity. Standard 3" adjustable leveling feet.

- Must select SD (28.5") for standard depth or ND (20") for narrow depth
- Must input 24", 36", 48", 60", 72" in length for part number
- Must select fuel type (LP) for Propane (NG) for Natural Gas
- See Equipment base spec sheets separately



**CHAR Products, LLC**

Ph. 702-489-9888

Fax. 702-489-9898

Website: [www.charprd.com](http://www.charprd.com)

Email: [info@charprd.com](mailto:info@charprd.com)

2915 Losee Rd. Ste 106

N. Las Vegas, NV 89030



MODEL #	LENGTH A	NARROW DEPTH B	STANDARD DEPTH B	BTU INPUT NG	BTU WITH FEATURE FLAME	SHIPPING WEIGHT ESTIMATED
CP-GFG-ROB-24-_-_-_-	24"	20"	28.5"	44,000	74,000	125 LBS.
CP-GFG-ROB-36-_-_-_-	36"	20"	28.5"	66,000	96,000	150 LBS.
CP-GFG-ROB-48-_-_-_-	48"	20"	28.5"	115,500	145,500	200 LBS.
CP-GFG-ROB-60-_-_-_-	60"	20"	28.5"	148,500	178,500	250 LBS.
CP-GFG-ROB-72-_-_-_-	72"	20"	28.5"	165,000	195,000	300 LBS.

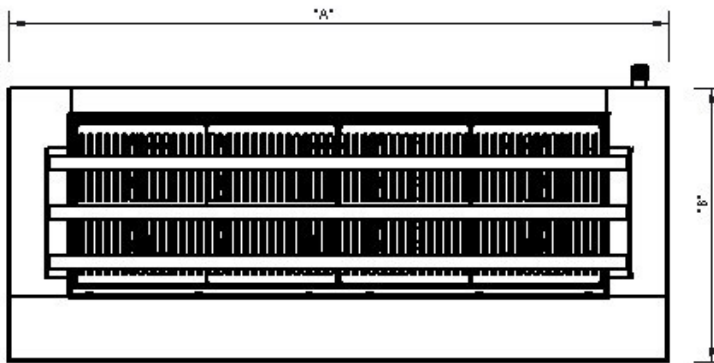

TOP

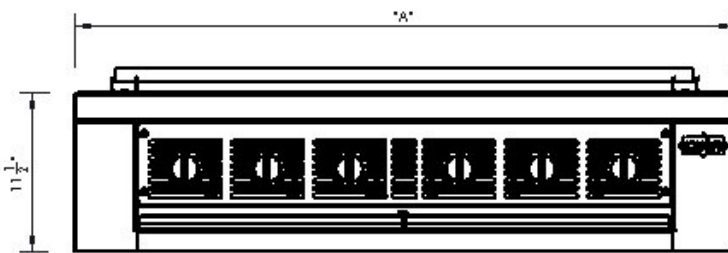

FRONT

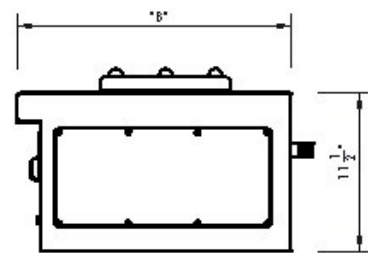

SIDE

### INSTALLATION INSTRUCTIONS

1. A properly sized gas line must be provided. All units are internally regulated. DO NOT DUAL REGULATE.
2. An adequate ventilation system is required for commercial use. DO NOT ATTEMPT TO OPERATE THIS EQUIPMENT WITHOUT IT.
3. Observe all local and national codes.
4. Proper combustion requires this unit to remain on 3" legs.
5. This appliance is manufactured for commercial use ONLY. It is NOT intended for residential indoor use.
6. We upgrade our products regularly and in doing so, materials, specifications, and model numbers are subject to change without notice.

**CHAR Products, LLC**

Ph. 702-489-9888

Fax. 702-489-9898

Website: [www.charprd.com](http://www.charprd.com)

Email: [info@charprd.com](mailto:info@charprd.com)

2915 Losee Rd. Ste 106

N. Las Vegas, NV 89030



# CHURRASCO GAS FUEL

## SPECIFICATION SHEET



### SPECIFICATIONS

The gas fueled CHAR Churrasco Broiler is available in single tier configurations in four different sizes. Each comes with rotating spits. A proven industrial gear motor offers years of uninterrupted operation of the rotating spits. To ensure performance and longevity these units are constructed entirely of 304 stainless steel and have a ceramic cloth exterior.

- See spec sheets for cabinet and table bases
- Must select length 36", 48", 60", 72"
- Must select gas type (LP) for Propane (NG) for Natural Gas



ITEM NO	
QUANTITY	
JOB NAME	
JOB NO	

### PART NUMBER DESIGNATION

**CP-GFG-CHU-** - - -

Length

Gas type (LP) for Propane (NG) for Natural Gas

Option code from option list

### STANDARD FEATURES

- 14 gauge stainless steel body
- Ceramic cloth insulated body
- Multiple gas control valves for precise heat control
- Over head resting rack
- Removable drip pans
- Adjustable leveling feet
- Skewers included
- 1/2" thick laser cut removable steel grates
- 3/4" gas connection
- Cleaning kit
- Appropriate gas regulator (for gas type selected)
- Two year warranty parts and labor

### OPTIONS

OPTION	DESCRIPTION
FQD	3/4" FLEX QUICK DISCONNECT
RPS	REMOVABLE 8" PLATE SHELF
SG	STAINLESS STEEL GRATE
FG	FISH GRATES
PSC	PLATE SHELF 1/6 PAN CONDIMENT INSERTS
GS	GAS SAFETY

CONSULTANT APPROVAL:

**CHAR Products, LLC**

Ph. 702-489-9888

Fax. 702-489-9898

Website: [www.charprd.com](http://www.charprd.com)

Email: [info@charprd.com](mailto:info@charprd.com)

2915 Losee Rd. Ste 106

N. Las Vegas, NV 89030

© copyright 2024



MODEL #	LENGTH A	FUEL LINE SIZE	ELECTRIC W/GAS SAFETY	BTU INPUT NG	SHIPPING WEIGHT ESTIMATED
CP-GFG-CHU-36-__-__	36"	3/4"	120V-1PH-10A	66,000	656 LBS.
CP-GFG-CHU-48-__-__	48"	3/4"	120V-1PH-10A	115,500	874 LBS.
CP-GFG-CHU-60-__-__	60"	3/4"	120V-1PH-10A	148,500	1,093 LBS.
CP-GFG-CHU-72-__-__	72"	3/4"	120V-1PH-10A	165,000	1,311 LBS.

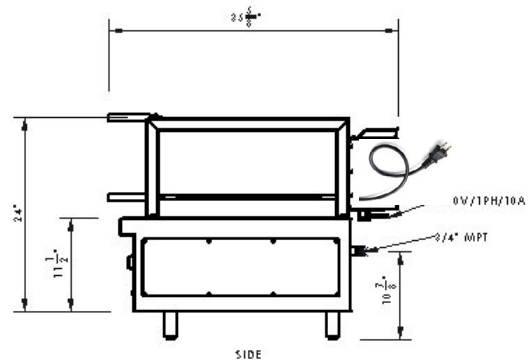
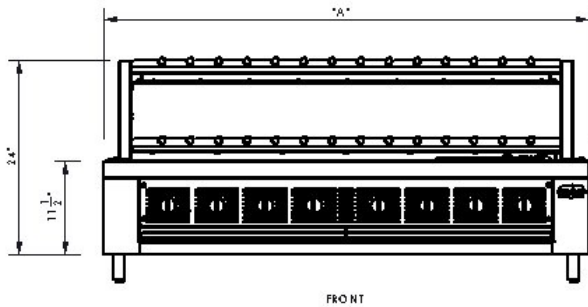
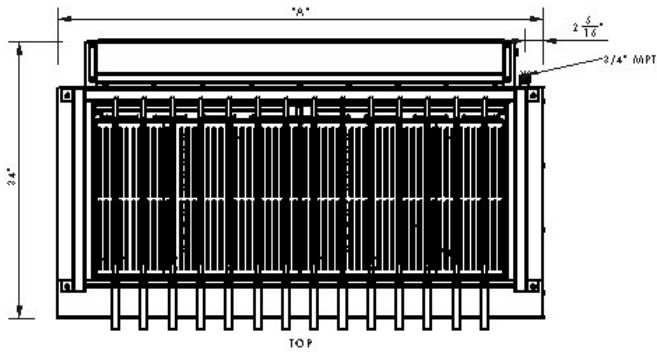

### INSTALLATION INSTRUCTIONS

1. A properly sized gas line must be provided. All units are internally regulated. DO NOT DUAL REGULATE.
2. An adequate ventilation system is required for commercial use. DO NOT ATTEMPT TO OPERATE THIS EQUIPMENT WITHOUT IT.
3. Observe all local and national codes.
4. Proper combustion requires this unit to remain on 3" legs.
5. This appliance is manufactured for commercial use ONLY. It is NOT intended for residential indoor use.
6. We upgrade our products regularly and in doing so, materials, specifications, and model numbers are subject to change without notice.

**CHAR Products, LLC**

Ph. 702-489-9888

Fax. 702-489-9898

Website: [www.charprd.com](http://www.charprd.com)

Email: [info@charprd.com](mailto:info@charprd.com)

2915 Losee Rd. Ste 106

N. Las Vegas, NV 89030

© copyright 2024





# PARILLA GAS FUELED GRILL

## SPECIFICATION SHEET



### SPECIFICATIONS

The CHAR Parilla Grill is manufactured to precise standards using 304 stainless steel full body construction and heavy duty support frame. Operator safety and comfort is strengthened through the use of ceramic lined exterior panels that prevent heat transfer. Enhanced cooking performance is achieved through the use of Stainless Steel Gas Burners. The Parilla Grill is available in 36", 48", 60" and 72" lengths to fit your needs.

- Please see spec sheets for cabinets and bases.
- Must select length 36", 48", 60", 72"
- Must select fuel type (LP) for Propane (NG) for Natural Gas

ITEM NO	
QUANTITY	
JOB NAME	
JOB NO	

### PART NUMBER DESIGNATION

CP-GFG-PAR-\_-\_-

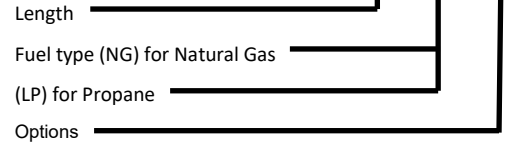

### STANDARD FEATURES

- Stainless steel construction
- Tilting Grates
- Fiber Ceramic insulation on perimeter
- Optional exterior finishes available
- Adjustable Feet
- Multiple gas valves for even heat
- Two years parts and labor warranty

### OPTIONS

OPTION	DESCRIPTION
FQD	48" FLEX QUICK DISCONNECT
R	ROTISSERIE
GP	1/2" POLISHED GRIDDLE PLATE
PS	PLATE SHELF
PSC	PLATE SHELF W/ CONDIMENT PAN
FF	FEATURE FLAME
CC	POWDERCOAT CUSTOM COLOR

CONSULTANT APPROVAL:

\_\_\_\_\_



CHAR Products, LLC

Ph. 702-489-9888

Fax. 702-489-9898

Website: www.charprd.com

Email: info@charprd.com

2915 Losee Rd. Ste 106

N. Las Vegas, NV 89030



MODEL #	LENGTH A	FUEL LINE SIZE	BTU INPUT NG	SHIPPING WEIGHT ESTIMATED
CP-GFG-PAR-36-__-__	36"	3/4"	66,000	300 LBS.
CP-GFG-PAR-48-__-__	48"	3/4"	115,500	450 LBS.
CP-GFG-PAR-60-__-__	60"	3/4"	148,500	600 LBS.
CP-GFG-PAR-72-__-__	72"	3/4"	165,000	800 LBS.

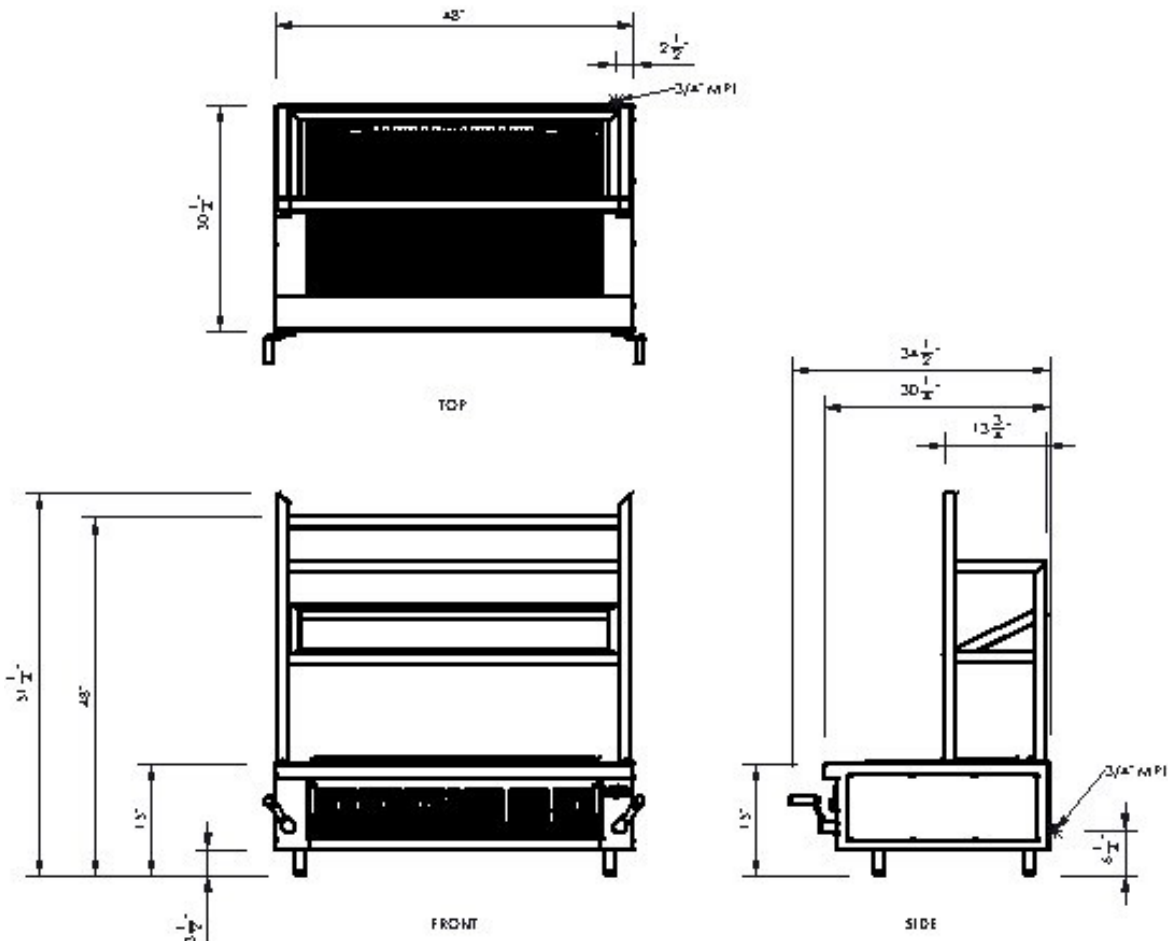

### INSTALLATION INSTRUCTIONS

1. A properly sized gas line must be provided. All units are internally regulated. DO NOT DUAL REGULATE.
2. An adequate ventilation system is required for commercial use. DO NOT ATTEMPT TO OPERATE THIS EQUIPMENT WITHOUT IT.
3. Observe all local and national codes.
4. Proper combustion requires this unit to remain on 3" legs.
5. This appliance is manufactured for commercial use ONLY. It is NOT intended for residential indoor use.
6. We upgrade our products regularly and in doing so, materials, specifications, and model numbers are subject to change without notice.

**CHAR Products, LLC**

Ph. 702-489-9888

Fax. 702-489-9898

Website: [www.charprd.com](http://www.charprd.com)

Email: [info@charprd.com](mailto:info@charprd.com)

2915 Losee Rd. Ste 106

N. Las Vegas, NV 89030



ITEM NO	
QUANTITY	
JOB NAME	
JOB NO	

**PART NUMBER DESIGNATION**

**CP-GFG-NRB-** \_ - -

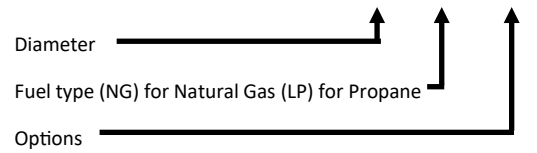

**STANDARD FEATURES**

- 14 Gauge stainless steel body
- Left and right side gas valves
- Removable drip pans
- Fully welded 14 gauge stainless steel fire box
- Ceramic cloth insulated perimeter
- 1/2" Thick laser cut removable steel grates
- Heavy duty locking swivel casters
- 1" gas connection
- Appropriate regulator for gas type selection
- Two year warranty parts and labor

**OPTIONS**

OPTION CODE	DESCRIPTION
GP	1/2" POLISHED GRIDDLE PLATE
FQD	48" GAS FLEX QUICK DISCONNECT
RPS	REMOVABLE PLATE SHELF 10"
PSC	PLATE SHELF 1/6 PAN W/CONDIMENT INSERT
FF	FEATURE FLAME

**ROUND BROILER NON-ROTATIONAL SPECIFICATION SHEET**



**SPECIFICATIONS**

The CHAR Round Broiler uses gas fuel. Available in 48" and 60" diameters. The unit serves as a heavy duty broiler and can function as a griddle when equipped with the high polished 1" thick removable stainless steel griddle plates. These units are equipped with heavy duty cast lift out burners and radiant panels. To ensure peak performance and longevity, these units are constructed entirely from 304 stainless steel and contain a ceramic cloth insulated exterior.

- Must select diameter 48,60 inch diameters
- Must select fuel type (NG) for Natural Gas (LP) for Propane

CONSULTANT APPROVAL:



**CHAR Products, LLC**

Ph. 702-489-9888

Fax. 702-489-9898

Website: www.charprd.com

Email: info@charprd.com

2915 Losee Rd. Ste 106

N. Las Vegas, NV 89030



MODEL #	DIAMETER A	GAS LINE SIZE	BTU INPUT NG	BTU W/FEATURE FLAME	SHIPPING WEIGHT ESTIMATED
CP-GFG-NRB-48-__	48"	1"	198,000	228,000	1,200 LBS.
CP-GFG-NRB-60-__	60"	1"	222,000	252,000	1,550 LBS.

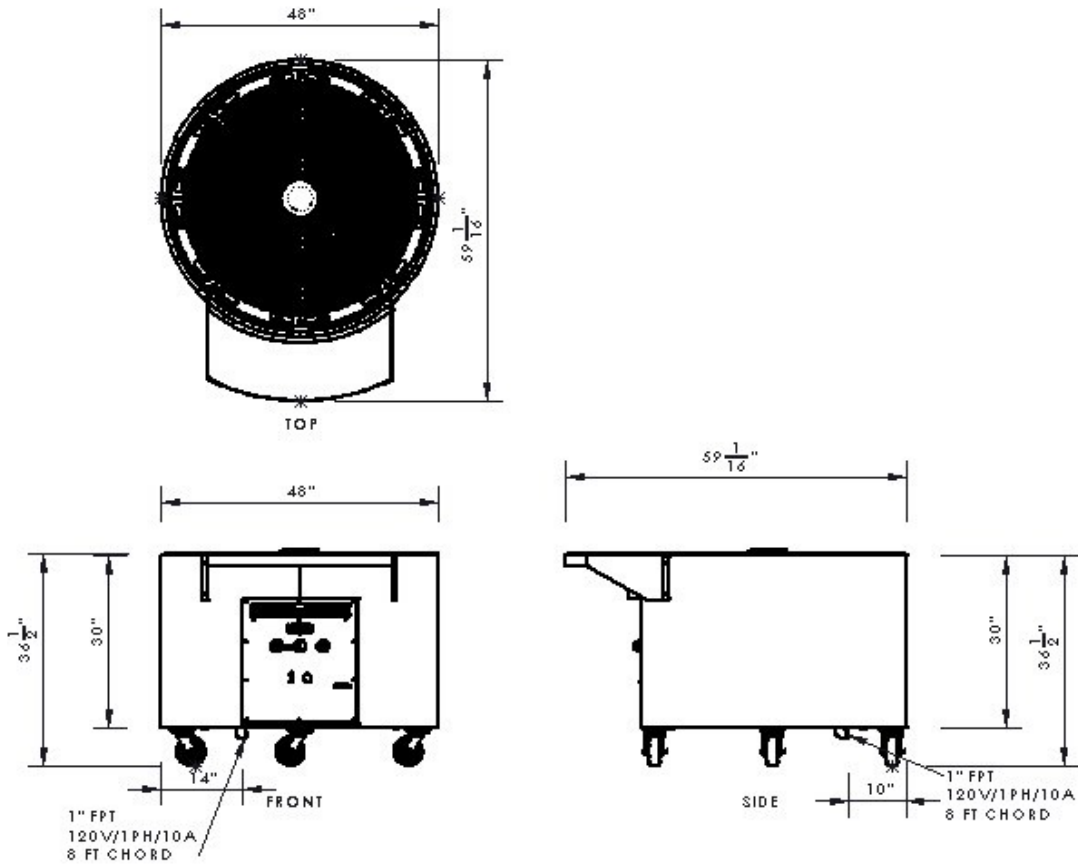

## INSTALLATION INSTRUCTIONS

1. A properly sized gas line must be provided. All units are internally regulated. DO NOT DUAL REGULATE.
2. An adequate ventilation system is required for commercial use. DO NOT ATTEMPT TO OPERATE THIS EQUIPMENT WITHOUT IT.
3. Observe all local and national codes.
4. Proper combustion requires this unit to remain on 6" casters
5. This appliance is manufactured for commercial use ONLY. It is NOT intended for residential indoor use.
6. We upgrade our products regularly and in doing so, materials, specifications, and model numbers are subject to change without notice.

**CHAR Products, LLC**

Ph. 702-489-9888

Fax. 702-489-9898

Website: [www.charprd.com](http://www.charprd.com)

Email: [info@charprd.com](mailto:info@charprd.com)

2915 Losee Rd. Ste 106

N. Las Vegas, NV 89030





# ROUND ROTATING BROILER

## SPECIFICATION SHEET



ITEM NO	
QUANTITY	
JOB NAME	
JOB NO	

### PART NUMBER DESIGNATION

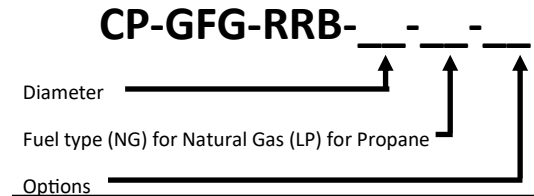

### STANDARD FEATURES

- 14 Gauge stainless steel body
- Left and right side gas valves
- Removable drip pans
- Fully welded 14 gauge stainless steel fire box
- Ceramic cloth insulated perimeter
- 1/2" Thick laser cut removable steel grates
- Heavy duty locking swivel casters
- 1" gas connection
- Appropriate regulator for gas type selection
- Two year warranty parts and labor

### OPTIONS

OPTION CODE	DESCRIPTION
GP	1/2" POLISHED GRIDDLE PLATE
FQD	48" GAS FLEX QUICK DISCONNECT
RPS	REMOVABLE PLATE SHELF 10"
PSC	PLATE SHELF 1/6 PAN W/CONDIMENT INSERT
FF	FEATURE FLAME

### SPECIFICATIONS

The CHAR Round Broiler uses gas fuel. Available in 38", 48" and 60" diameters. The unit serves as a heavy duty broiler and can function as a griddle when equipped with the high polished 1" thick removable stainless steel griddle plates. These units are equipped with heavy duty cast lift out burners and radiant panels. To ensure peak performance and longevity, these units are constructed entirely from 304 stainless steel and contain a ceramic cloth insulated exterior.

- Must select diameter 48,60 inch diameters
- Must select fuel type (NG) for Natural Gas (LP) for Propane



CONSULTANT APPROVAL:

<b>CHAR Products, LLC</b>	Ph. 702-489-9888	Website: <a href="http://www.charprd.com">www.charprd.com</a>	2915 Losee Rd. Ste 106
	Fax. 702-489-9898	Email: <a href="mailto:info@charprd.com">info@charprd.com</a>	N. Las Vegas, NV 89030



MODEL #	DIAMETER A	HEIGHT	ELECTRICAL	BTU INPUT NG	BTU W/FEATURE FLAME	SHIPPING WEIGHT ESTIMATED
CP-GFG-RRB-48-__	48"	36.5"	120V-1PH-8A	198,000	228,000	1,200 LBS.
CP-GFG-RRB-60-__	60"	36.5"	120V-1PH-8A	222,000	252,000	1,550 LBS.

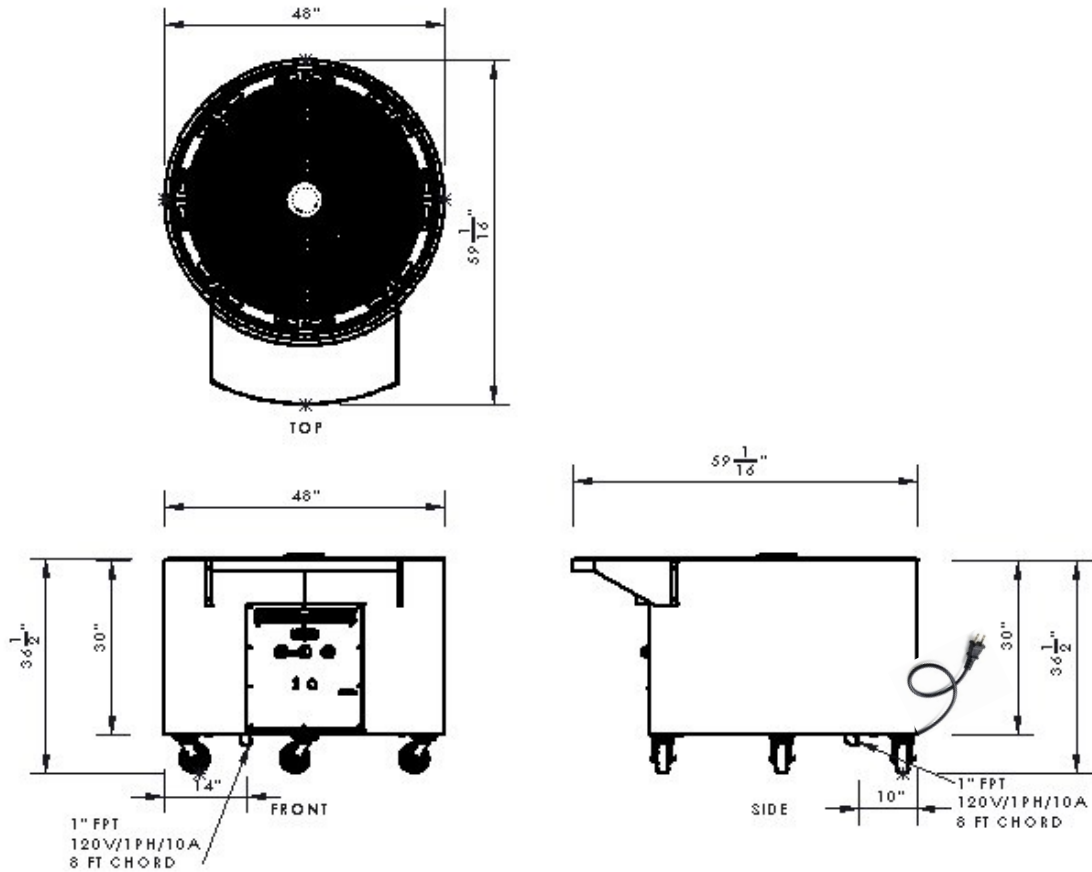

## INSTALLATION INSTRUCTIONS

1. A properly sized gas line must be provided. All units are internally regulated. DO NOT DUAL REGULATE.
2. An adequate ventilation system is required for commercial use. DO NOT ATTEMPT TO OPERATE THIS EQUIPMENT WITHOUT IT.
3. Observe all local and national codes.
4. Proper combustion requires this unit to remain on 6" casters
5. This appliance is manufactured for commercial use ONLY. It is NOT intended for residential indoor use.
6. We upgrade our products regularly and in doing so, materials, specifications, and model numbers are subject to change without notice.

**CHAR Products, LLC**

Ph. 702-489-9888

Fax. 702-489-9898

Website: [www.charprd.com](http://www.charprd.com)

Email: [info@charprd.com](mailto:info@charprd.com)

2915 Losee Rd. Ste 106

N. Las Vegas, NV 89030



# ROUND PLANCHA GAS FUELED

## SPECIFICATION SHEET



### SPECIFICATIONS

The CHAR gas fueled Round Plancha is available in 40", 48" and 60" diameters. This unit serves as a heavy duty griddle with high polished stainless steel plate cooking surface. To ensure performance and longevity, these units are constructed entirely of 304 stainless steel. Add the optional rotation feature to showcase the grilling experience. Utilizing a tested and proven industrial gear motor, this units option will provide years of uninterrupted operation of the rotating grill surface. Adjustability achieved with a rotational speed controller. This Round Plancha will be the highlight of the cooking experience.

- Must select from gas type (LP) for Propane (NG) for Natural as
- Gas safety is standard
- .Must choose size 40", 48", 60"



ITEM NO	
QUANTITY	
JOB NAME	
JOB NO	

### PART NUMBER DESIGNATION

**CP-GFG- RPL- - - -**

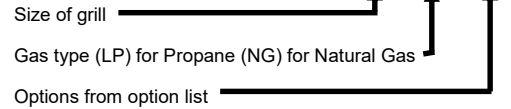

### STANDARD FEATURES

- 14 gauge stainless steel body
- Left and right side gas valves
- Removable drip tray
- Fully welded 14 gauge stainless steel drip rail
- 1/2" thick laser cut high polished stainless steel griddle plate
- 3/4" gas connection
- Appropriate regulator for gas type selected
- 6" Casters
- Two year warranty parts and labor

### OPTIONS

OPTION	DESCRIPTION
RGP	ROTATING GRILL PLATE
RPS	REMOVABLE 10" PLATE SHELF
PSC	PLATE SHELF 1/6 PAN CONDI-

CONSULTANT APPROVAL:

---

CHAR Products, LLC

Ph. 702-489-9888

Website: www.charprd.com

2915 Losee Rd. Ste 106

N. Las Vegas, NV 89030

© copyright 2024



MODEL #	LENGTH & WIDTH A	FUEL LINE SIZE	ELECTRIC W/GAS SAFETY	BTU INPUT NG	SHIPPING WEIGHT ESTIMATED
CP-GFG-RPL-40-_-_-	40	3/4"	120V-1PH-10A	168,000	475 LBS.
CP-GFG-RPL-48-_-_-	48	3/4"	120V-1PH-10A	198,000	550 LBS.
CP-GFG-RPL-60-_-_-	60	3/4"	120V-1PH-10A	222,000	675 LBS.

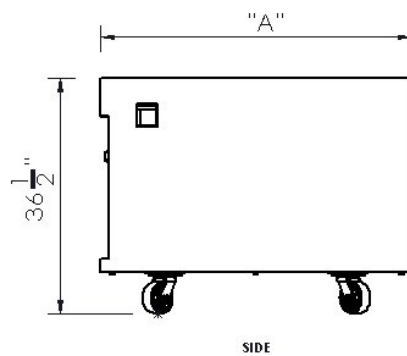
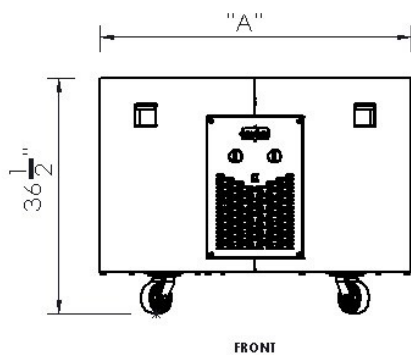
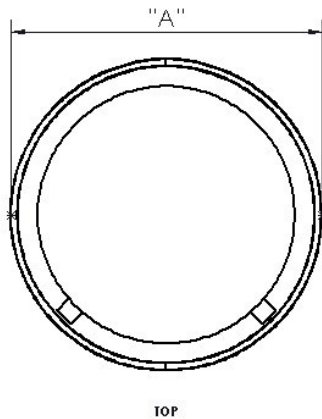

### INSTALLATION INSTRUCTIONS

1. A properly sized gas line must be provided. All units are internally regulated. DO NOT DUAL REGULATE
2. An adequate ventilation system is required for commercial use. DO NOT ATTEMPT TO OPERATE THIS EQUIPMENT WITHOUT IT.
3. Observe all local and national codes.
4. Proper combustion requires this unit to remain on casters or legs
5. This appliance is manufactured for commercial use ONLY. It is NOT intended for residential indoor use.
6. We upgrade our products regularly and in doing so, materials, specifications, and model numbers are subject to change without notice.

**CHAR Products, LLC**

Ph. 702-489-9888

Fax. 702-489-9898

Website: [www.charprd.com](http://www.charprd.com)

Email: [info@charprd.com](mailto:info@charprd.com)

2915 Losee Rd. Ste 106

N. Las Vegas, NV 89030



# TORTILLA GRILL

## SPECIFICATION SHEET



### SPECIFICATIONS

The CHAR gas fueled Tortilla Grill is available in 36", 48" and 60" diameters. This unit serves as a heavy duty griddle, plancha, and tortilla grill with high polished stainless steel plate cooking surface. To ensure performance and longevity, these units are constructed entirely of 304 stainless steel. Add the optional rotation feature to showcase the grilling experience. Utilizing a tested and proven industrial gear motor, this units option will provide years of uninterrupted operation of the rotating grill surface. Adjustability achieved with a rotational speed controller. This tortilla grill will be the highlight of the cooking experience.

- Must select from gas type options (LP) for propane (NG) for natural gas
- Gas safety is standard

ITEM NO	
QUANTITY	
JOB NAME	
JOB NO	

### PART NUMBER DESIGNATION

**CP-GFG- RSQTG- - - -**

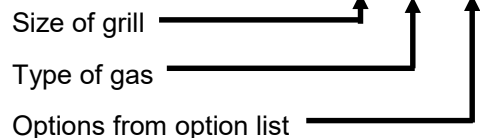

### STANDARD FEATURES

- 14 gauge stainless steel body
- Left and right side gas valves
- Removable drip tray
- Fully welded 14 gauge stainless steel drip rail
- 1/2" thick laser cut high polished stainless steel griddle plate
- 3/4" gas connection
- Appropriate regulator for gas type selected
- 6" legs standard
- Two year warranty parts and labor

### OPTIONS

OPTION CODE	DESCRIPTION
RGP	ROTATING GRILL PLATE
RPS	REMOVABLE 10" PLATE SHELF
PSC	PLATE SHELF 1/6 PAN CONDIMENT INSERTS
C	6" CASTER KIT
GS	GAS SAFETY

CONSULTANT APPROVAL:

---



**CHAR Products, LLC**

Ph. 702-489-9888

Fax. 702-489-9898

Website: [www.charprd.com](http://www.charprd.com)

Email: [info@charprd.com](mailto:info@charprd.com)

2915 Losee Rd. Ste 106

N. Las Vegas, NV 89030

© copyright 2024





MODEL #	LENGTH & WIDTH A	HEIGHT	FUEL LINE SIZE	ELECTRIC W/GAS SAFETY	BTU INPUT NG	SHIPPING WEIGHT ESTIMATED
CP-GFG- RSQTG-36-__-__	36"x36"	36"	3/4"	120V-1PH-10A	168,000	475 LBS.
CP-GFG- RSQTG-48-__-__	48"x48"	36"	3/4"	120V-1PH-10A	198,000	550 LBS.
CP-GFG- RSQTG-60-__-__	60"x60"	36"	3/4"	120V-1PH-10A	222,000	675 LBS.

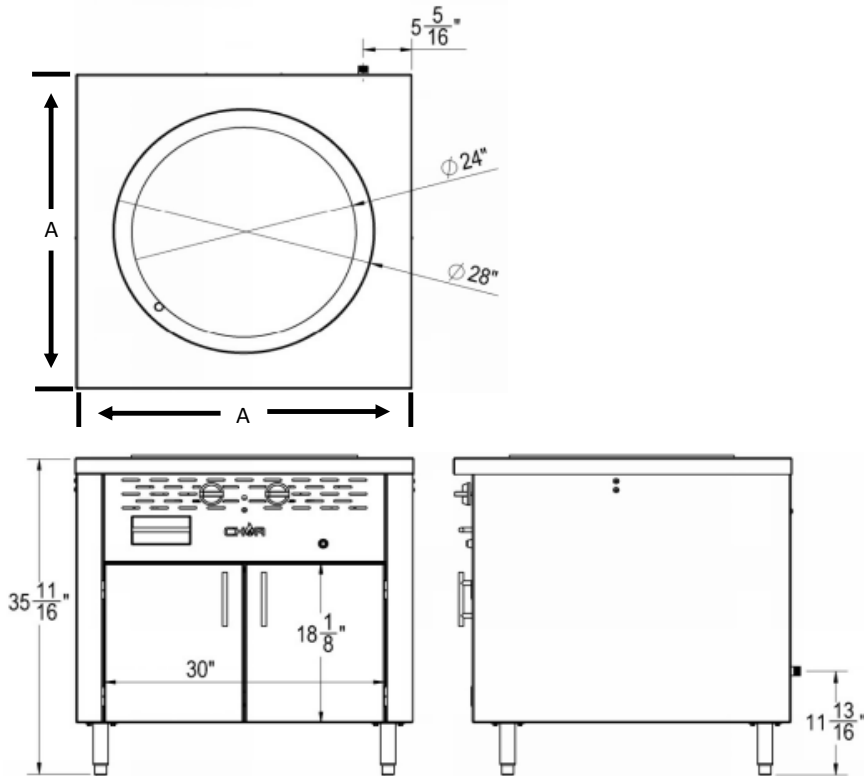

### INSTALLATION INSTRUCTIONS

1. A properly sized gas line must be provided. All units are internally regulated. DO NOT DUAL REGULATE
2. An adequate ventilation system is required for commercial use. DO NOT ATTEMPT TO OPERATE THIS EQUIPMENT WITHOUT IT.
3. Observe all local and national codes.
4. Proper combustion requires this unit to remain on casters or legs
5. This appliance is manufactured for commercial use ONLY. It is NOT intended for residential indoor use.
6. We upgrade our products regularly and in doing so, materials, specifications, and model numbers are subject to change without notice.

**CHAR Products, LLC**

Ph. 702-489-9888

Fax. 702-489-9898

Website: [www.charprd.com](http://www.charprd.com)

Email: [info@charprd.com](mailto:info@charprd.com)

2915 Losee Rd. Ste 106

N. Las Vegas, NV 89030

© copyright 2024



# SARJ GAS FUEL

## SPECIFICATION SHEET

ITEM NO	
QUANTITY	
JOB NAME	
JOB NO	

### PART NUMBER DESIGNATION

**CP-GFG-SARJ-** - -

Fuel type (LP) for Propane (NG) for Natural Gas

Option code from option list

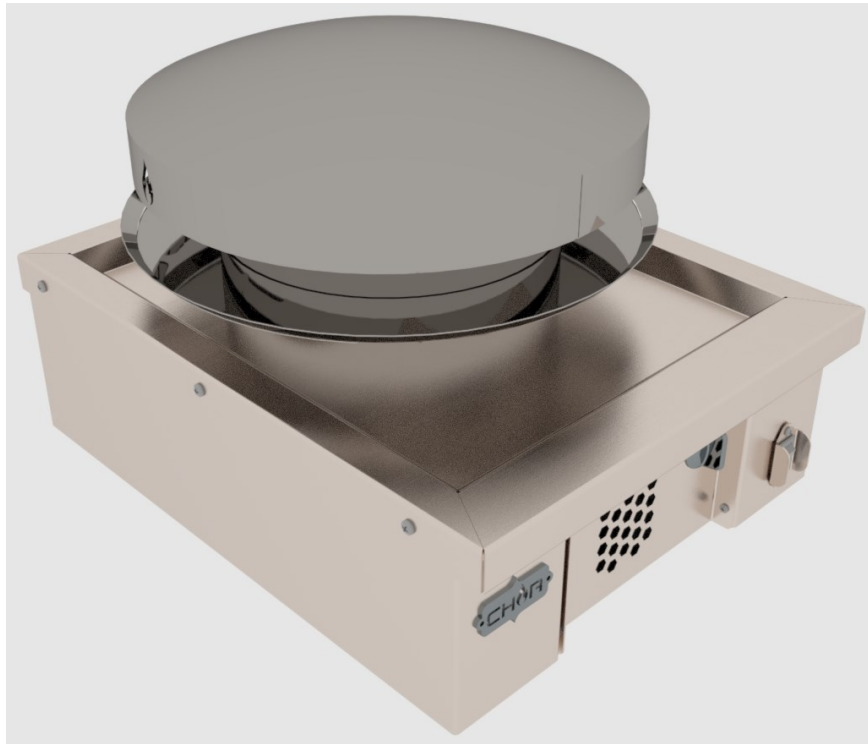

### STANDARD FEATURES

- 14 gauge stainless steel body
- Domed grill surface
- Adjustable gas valve
- Full gas safety and igniter
- Grease drip ring
- Adjustable leveling feet
- 1/2" gas line
- Appropriate gas regulator (for gas type selected)
- Gas safety
- Two year warranty parts and labor

OPTIONS	
OPTION CODE	DESCRIPTION
FQD	1/2" FLEX QUICK DISCONNECT

### SPECIFICATIONS

The CHAR gas fueled Sarj Grill is great for for cooking items such as naan breads. This unit has a heavy duty domed grill surface and is easily placed on or into a counter. To ensure performance and longevity these units are constructed entirely of 304 stainless steel.

- See spec sheets for cabinet and table bases
- Must choose fuel type (LP) for Propane (NG) for Natural Gas

CONSULTANT APPROVAL:

---



**CHAR Products, LLC**

Ph. 702-489-9888

Fax. 702-489-9898

Website: [www.charprd.com](http://www.charprd.com)

Email: [info@charprd.com](mailto:info@charprd.com)

2915 Losee Rd. Ste 106

N. Las Vegas, NV 89030



MODEL #	LENGTH	WIDTH	HEIGHT	FUEL LINE SIZE	ELECTRIC W/GAS SAFETY	BTU INPUT-NG	SHIPPING WEIGHT ESTIMATED
CP-GFG-SARJ-__	20 7/16	24 5/8	17 9/16	1/2	120V-1PH-5A	90,000	180 LBS.

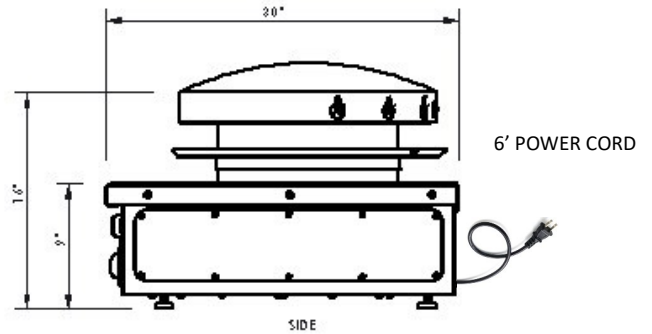
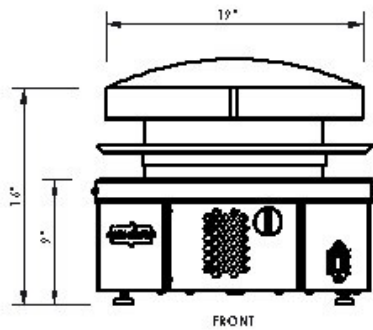
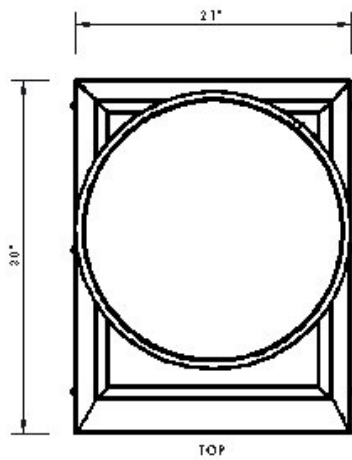

### INSTALLATION INSTRUCTIONS

1. An appropriate gas line must be provided. All units are internally regulated. DO NOT DUAL REGULATE.
2. An adequate ventilation system is required for commercial use. DO NOT ATTEMPT TO OPERATE THIS EQUIPMENT WITHOUT IT.
3. Observe all local and national codes.
4. Proper combustion requires this unit to remain on legs.
5. This appliance is manufactured for commercial use ONLY. It is NOT intended for residential indoor use.
6. We upgrade our products regularly and in doing so, materials, specifications, and model numbers are subject to change without notice.

**CHAR Products, LLC**

Ph. 702-489-9888

Fax. 702-489-9898

Website: [www.charprd.com](http://www.charprd.com)

Email: [info@charprd.com](mailto:info@charprd.com)

2915 Losee Rd. Ste 106

N. Las Vegas, NV 89030

© copyright 2024



# VERTICAL ROTISSERIE

## SPECIFICATION SHEET

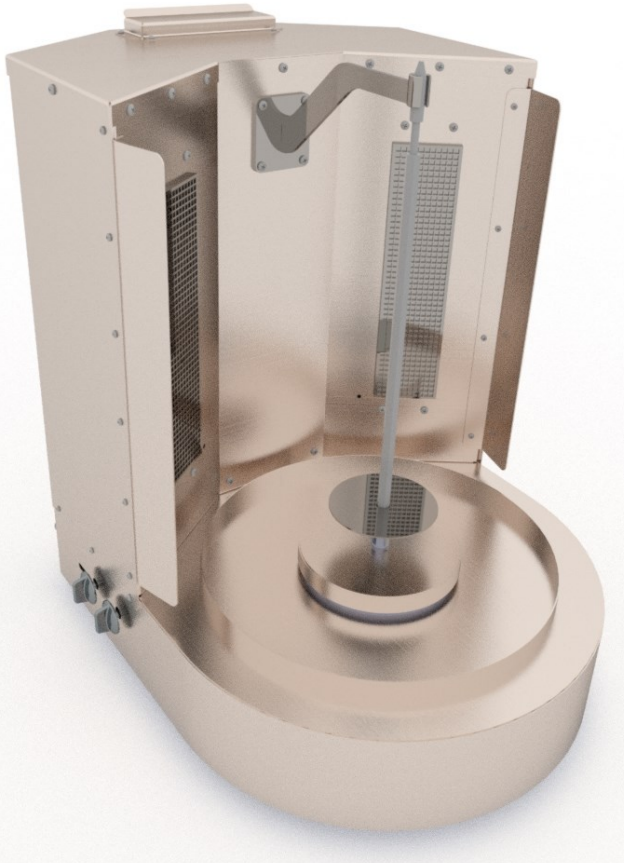

### SPECIFICATIONS

The CHAR Vertical Rotisserie is engineered for simple and secure skewer installation and removal. Gas Fueled, this infrared heat source is available in 33"x22". Smooth gear drive motion and offset heat sources provide uniform coverage of all available cooking area. The fully insulated exterior façade and interior base to ensure safe operation. Heavy duty stainless steel construction provides stability and longevity of the Vertical Rotisserie

- Must select gas type (LP) for Propane (NG) for Natural Gas

ITEM NO	
QUANTITY	
JOB NAME	
JOB NO	

### PART NUMBER DESIGNATION

**CP-GFG-VRTROT-**

Gas type (LP) for Propane (NG) for Natural Gas

Option code from option list

### STANDARD FEATURES

- Full stainless steel construction
- Fully insulated, both interior and exterior
- Custom turned spit assembly includes 2 ea
- Full gas safety
- Removable drip pan
- Adjustable leveling feet
- 45 lb. spit capacity
- 3/4" gas connection
- Adjustable leveling feet
- Appropriate gas regulator (for gas type selected)
- Two year warranty parts and labor

### OPTIONS

OPTION CODE	DESCRIPTION
FHS	FOLD OUT HEAT SHIELDS
E120V	ELECTRICAL 120V/750W
E240V	ELECTRICAL 240V/750W
SA	SKEWER ASSEMBLY

CONSULTANT APPROVAL:



**CHAR Products, LLC**

Ph. 702-489-9888

Fax. 702-489-9898

Website: www.charprd.com

Email: info@charprd.com

2915 Losee Rd. Ste 106

N. Las Vegas, NV 89030

© copyright 2024



MODEL #	LENGTH	WIDTH	FUEL LINE SIZE	ELECTRIC W/GAS SAFETY	BTU INPUT	SHIPPING WEIGHT ESTIMATED
CP-GFG-VRTROT-__-__	32 5/8"	31 5/16"	3/4"	120V-1PH-10A	65,000	350 LBS.

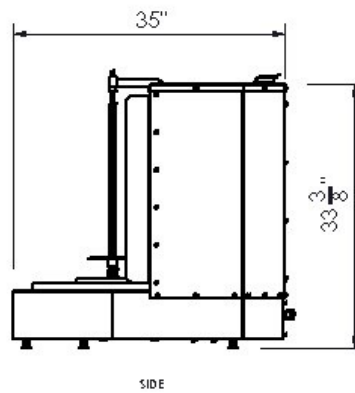
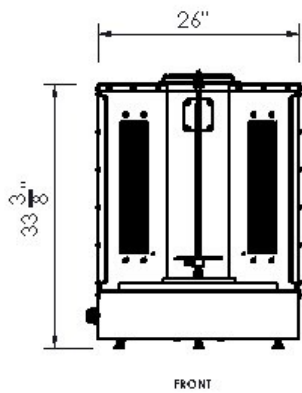
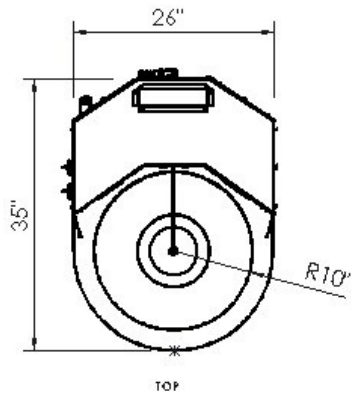

### INSTALLATION INSTRUCTIONS

1. A properly sized gas line must be provided. All units are internally regulated. DO NOT DUAL REGULATE.
2. An adequate ventilation system is required for commercial use. DO NOT ATTEMPT TO OPERATE THIS EQUIPMENT WITHOUT IT.
3. Observe all local and national codes.
4. Proper combustion requires this unit to remain on 3" legs.
5. This appliance is manufactured for commercial use ONLY. It is NOT intended for residential indoor use.
6. We upgrade our products regularly and in doing so, materials, specifications, and model numbers are subject to change without notice.

**CHAR Products, LLC**

Ph. 702-489-9888

Fax. 702-489-9898

Website: [www.charprd.com](http://www.charprd.com)

Email: [info@charprd.com](mailto:info@charprd.com)

2915 Losee Rd. Ste 106

N. Las Vegas, NV 89030

© copyright 2024





## **AMBIENT**

**CHAR® Products produces Ambient temperature showcase equipment that allows you to highlight and display your products.**

---





ITEM NO	
QUANTITY	
JOB NAME	
JOB NO	

# ROUND ROTATING DESSERT DISPLAY

## SPECIFICATION SHEET



### PART NUMBER DESIGNATION

**CP-RRDD-36-**

Option code from option list



### STANDARD FEATURES

- 1/2" Thick tempered glass shelves
- Segmented bottom shelf for easy cleaning
- Dual speed controls
- Full 304 stainless steel construction
- Mirror finish stainless steel center column
- Heavy duty drive motor
- Two year warranty parts and labor

### OPTIONS

OPTION CODE	DESCRIPTION
NP	NEMA 5-15 115V PLUG
SGS	STARFIRE GLASS SHELVES
LD	LOCKING CABINET DOORS
SSCBC	STAINLESS STEEL CABINET BASE W/ COUNTER TOP
SSCBNC	STAINLESS STEEL CABINET BASE NO COUNTER TOP

### SPECIFICATIONS

The CHAR Round Rotating Dessert Display is a glass, three tier product display unit. This ambient temperature display case elegantly shows any dessert pastry product in a 360 degree view for maximum presentation. Speed control allows for the setting at optimal viewing pleasure and can be slowed down or turned off easily. Designed to be integral to a counter with the base hidden behind the cabinet and only the glass shelves visible. The bottom glass section is in four segments for easy removal and cleaning. The upper glass shelves are easily cleaned from the top and bottom.

CONSULTANT APPROVAL:

---



**CHAR Products, LLC**

Ph. 702-489-9888

Fax. 702-489-9898

Website: [www.charprd.com](http://www.charprd.com)

Email: [info@charprd.com](mailto:info@charprd.com)

2915 Losee Rd. Ste 106

N. Las Vegas, NV 89030

© copyright 2024



MODEL #	STANDARD DIAMETER	ELECTRIC	SHIPPING WEIGHT ESTIMATED
CP-RRDD-36-__	36	120V-1PH-20A	650 LBS.

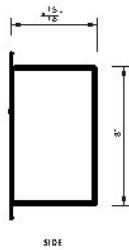
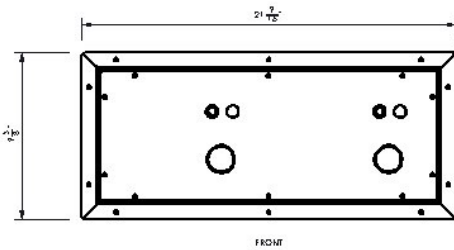
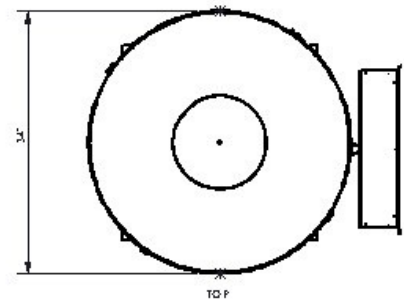
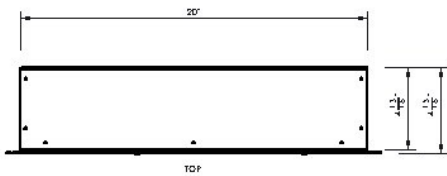

Control box for Dessert Display

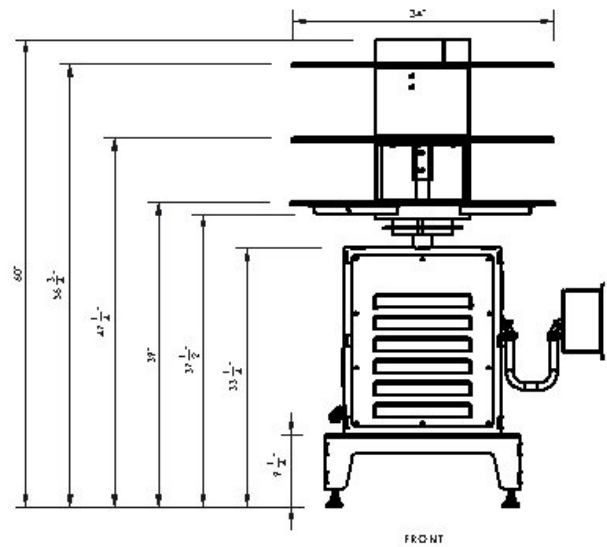

### INSTALLATION INSTRUCTIONS

1. Observe all local and national codes.
2. This appliance is manufactured for commercial use ONLY. It is NOT intended for residential indoor use.
3. We upgrade our products regularly and in doing so, materials, specifications, and model numbers are subject to change without notice.

**CHAR Products, LLC**

Ph. 702-489-9888

Fax. 702-489-9898

Website: [www.charprd.com](http://www.charprd.com)

Email: [info@charprd.com](mailto:info@charprd.com)

2915 Losee Rd. Ste 106

N. Las Vegas, NV 89030



# EQUIPMENT BASE AMBIENT

## SPECIFICATION SHEET

ITEM NO	
QUANTITY	
JOB NAME	
JOB NO	

### PART NUMBER DESIGNATION

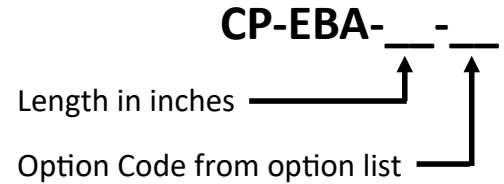

### STANDARD FEATURES

- Stainless steel interior and exterior
- Heavy Duty 6" adjustable legs
- Two year warranty: parts & labor



\*SHOWN WITH OPTIONAL CASTERS AND SWING DOORS

OPTIONS	
OPTION CODE	DESCRIPTION
C	FOUR 6" ROLLING CASTERS
CS	CUSTOM SHELVING
DR	DOORS

### SPECIFICATIONS

CHAR Products has over 20 years experience designing, engineering and manufacturing commercial kitchen equipment. Our products reside all over the United States, in some of the most prestigious establishments.

Contact our sales team and see what we can do for your next Freezer Equipment Base project.

CONSULTANT APPROVAL:

---



**CHAR Products, LLC**

Ph. 702-489-9888

Fax. 702-489-9898

Website: [www.charprd.com](http://www.charprd.com)

Email: [info@charprd.com](mailto:info@charprd.com)

2915 Losee Rd. Ste 106

N. Las Vegas, NV 89030





MODEL #	LENGTH A	SHIPPING WEIGHT ESTIMATED
CP-EBA-36-__	36"	275 LBS.
CP-EBA-48-__	48"	300 LBS.
CP-EBA-60-__	60"	325 LBS.
CP-EBA-72-__	72"	375 LBS.

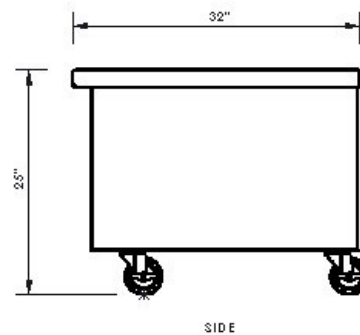
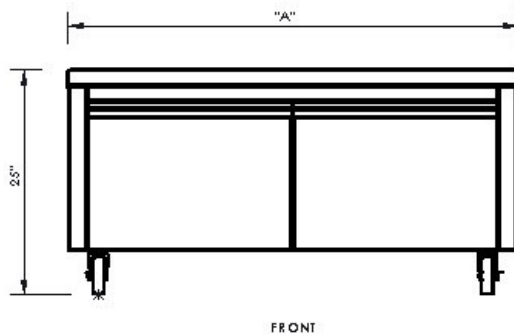
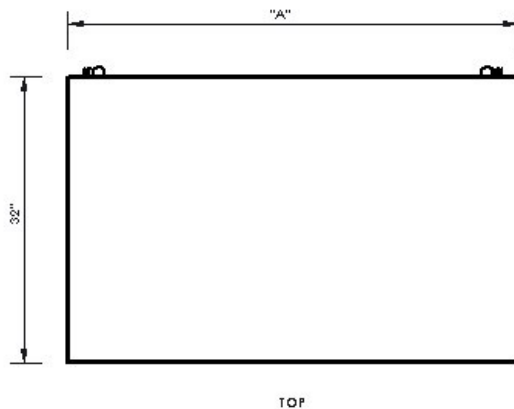

### INSTALLATION INSTRUCTIONS

1. Observe all local and national codes.
2. This appliance is manufactured for commercial use ONLY. It is NOT intended for residential indoor use.
3. We upgrade our products regularly and in doing so, materials, specifications, and model numbers are subject to change without notice.

**CHAR Products, LLC**

Ph. 702-489-9888

Fax. 702-489-9898

Website: [www.charprd.com](http://www.charprd.com)

Email: [info@charprd.com](mailto:info@charprd.com)

2915 Losee Rd. Ste 106

N. Las Vegas, NV 89030



ITEM NO	
QUANTITY	
JOB NAME	
JOB NO	

# EQUIPMENT BASE TUBE FRAME

## SPECIFICATION SHEET



\*SHOWN WITH OPTIONAL CASTERS

### PART NUMBER DESIGNATION



### STANDARD FEATURES

- 6" Adjustable legs
- Fully tig welded stainless steel frame.
- 32" counter top depth

### OPTIONS

OPTION CODE	DESCRIPTION
C	6" LOCKING CASTERS

### SPECIFICATIONS

The CHAR Equipment Base Tube Frame is a great addition to any commercial kitchen or food prep area. With a standard depth of 32" the table top is available in 36", 48", 60", 72", 96" lengths. This equipment base can be used to hold any of our table top grills from a Robata to a tortilla grill as well as a freezer pan or cold rail.

- Must select length



CONSULTANT APPROVAL:

---

<b>CHAR Products, LLC</b>	Ph. 702-489-9888	Website: <a href="http://www.charprd.com">www.charprd.com</a>	2915 Losee Rd. Ste 106
	Fax. 702-489-9898	Email: <a href="mailto:info@charprd.com">info@charprd.com</a>	N. Las Vegas, NV 89030



MODEL #	LENGTH A	WEIGHT CAPACITY	SHIPPING WEIGHT ESTIMATED
CP-EBTF-36-__-__	36"	400 LBS.	150 LBS.
CP-EBTF-48-__-__	48"	400 LBS.	200 LBS.
CP-EBTF-60-__-__	60"	400 LBS.	250 LBS.
CP-EBTF-72-__-__	72"	400 LBS.	300 LBS.
CP-EBTF-96-__-__	96"	400 LBS.	350 LBS.

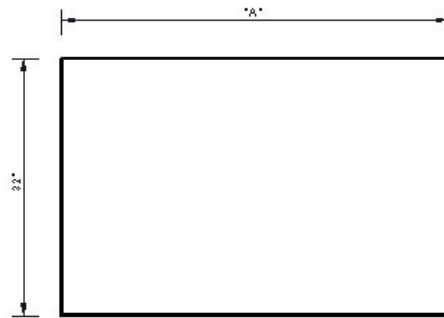

TOP

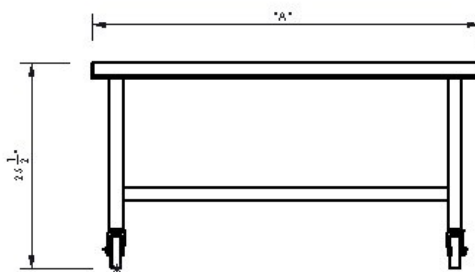

FRONT

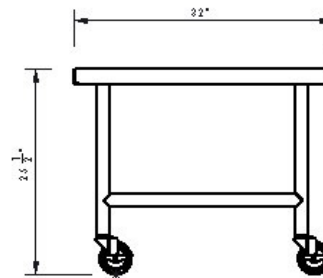

SIDE

### INSTALLATION INSTRUCTIONS

1. Observe all local and national codes.
2. This appliance is manufactured for commercial use ONLY. It is NOT intended for residential use.
3. We upgrade our products regularly and in doing so, materials, specifications, and model numbers are subject to change without notice.

**CHAR Products, LLC**

Ph. 702-489-9888

Fax. 702-489-9898

Website: [www.charprd.com](http://www.charprd.com)

Email: [info@charprd.com](mailto:info@charprd.com)

2915 Losee Rd. Ste 106

N. Las Vegas, NV 89030

## RADIANT

**At CHAR® Products, we create radiant showcase equipment, making the front of house experience unique and unforgettable. Let us take your creative ideas and turn them into the center piece of your next project.**

---



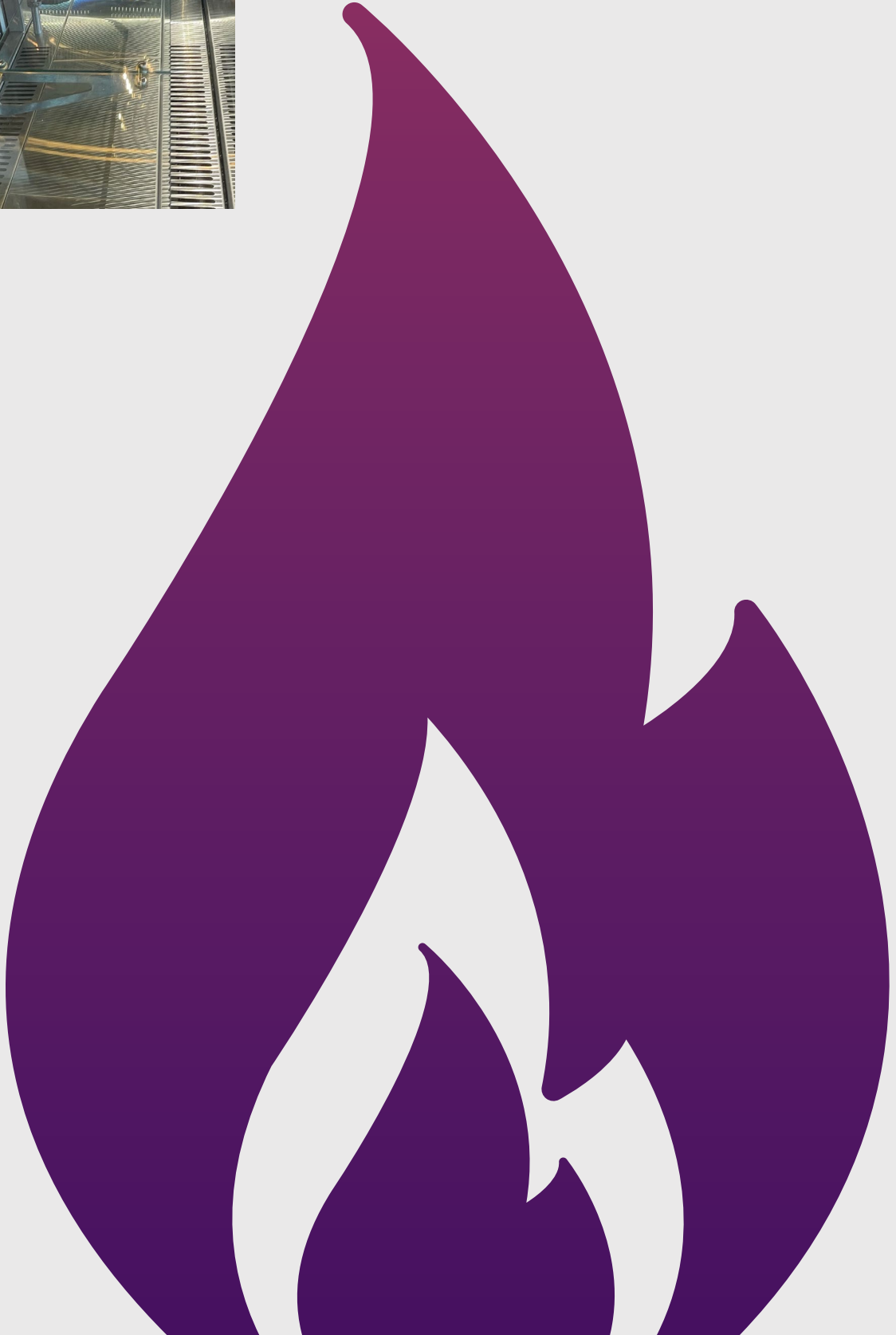
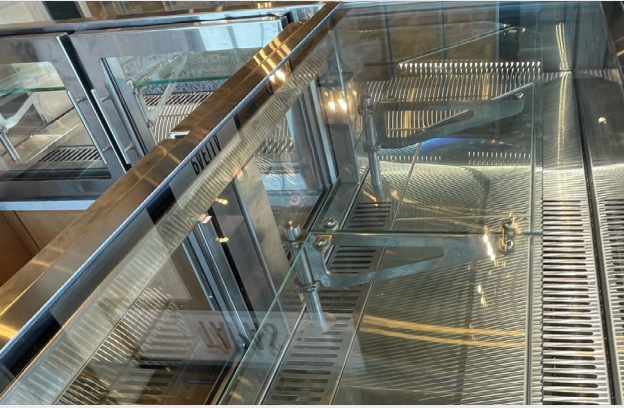







## THANK YOU

CHAR® Products would like to thank you for your choice to take a look at our offerings. It is our intent to develop lasting customer relations. We take pride in our products. Our goal is for the quality and functionality of the last piece of equipment sold to sell the next. Again, thank you. We hope, that in the future, you will choose to make CHAR® Products your choice for custom equipment that will...

*Ignite Your Imagination*

---

### Contact our sales team:

Office (702) 489-9888  
Fax (702) 489-9898  
Email [info@charprd.com](mailto:info@charprd.com)  
Website [www.charprd.com](http://www.charprd.com)  
Address: Char Products, LLC  
2915 Losee Road Ste 106  
North Las Vegas, NV 89030



1.702.489.9888 • [info@charprd.com](mailto:info@charprd.com) • [charprd.com](http://charprd.com)  
2915 Losee Road Suite 106, North Las Vegas, NV 89030

