



# TORTILLA GRILL

## SPECIFICATION SHEET



ITEM NO	
QUANTITY	
JOB NAME	
JOB NO	

### PART NUMBER DESIGNATION

**CP-GFG- RSQTG-** - - -

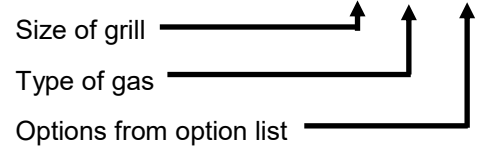

### STANDARD FEATURES

- 14 gauge stainless steel body
- Left and right side gas valves
- Removable drip tray
- Fully welded 14 gauge stainless steel drip rail
- 1/2" thick laser cut high polished stainless steel griddle plate
- 3/4" gas connection
- Appropriate regulator for gas type selected
- 6" legs standard
- Two year warranty parts and labor

### OPTIONS

OPTION CODE	DESCRIPTION
RGP	ROTATING GRILL PLATE
RPS	REMOVABLE 10" PLATE SHELF
PSC	PLATE SHELF 1/6 PAN CONDI-MENT INSERTS
C	6" CASTER KIT
GS	GAS SAFETY

### SPECIFICATIONS

The CHAR gas fueled Tortilla Grill is available in 36", 48" and 60" diameters. This unit serves as a heavy duty griddle, plancha, and tortilla grill with high polished stainless steel plate cooking surface. To ensure performance and longevity, these units are constructed entirely of 304 stainless steel. Add the optional rotation feature to showcase the grilling experience. Utilizing a tested and proven industrial gear motor, this unit's option will provide years of uninterrupted operation of the rotating grill surface. Adjustability achieved with a rotational speed controller. This tortilla grill will be the highlight of the cooking experience.

- Must select from gas type options (LP) for propane (NG) for natural gas
- Gas safety is standard

CONSULTANT APPROVAL:

---



<b>CHAR Products, LLC</b>	Ph. 702-489-9888	Website: <a href="http://www.charprd.com">www.charprd.com</a>	2915 Losee Rd. Ste 106
	Fax. 702-489-9898	Email: <a href="mailto:info@charprd.com">info@charprd.com</a>	N. Las Vegas, NV 89030



MODEL #	LENGTH & WIDTH A	HEIGHT	FUEL LINE SIZE	ELECTRIC W/GAS SAFETY	BTU INPUT NG	SHIPPING WEIGHT ESTIMATED
CP-GFG-RSQTG-36-__-__	36"x36"	36"	3/4"	120V-1PH-10A	168,000	475 LBS.
CP-GFG-RSQTG-48-__-__	48"x48"	36"	3/4"	120V-1PH-10A	198,000	550 LBS.
CP-GFG-RSQTG-60-__-__	60"x60"	36"	3/4"	120V-1PH-10A	222,000	675 LBS.

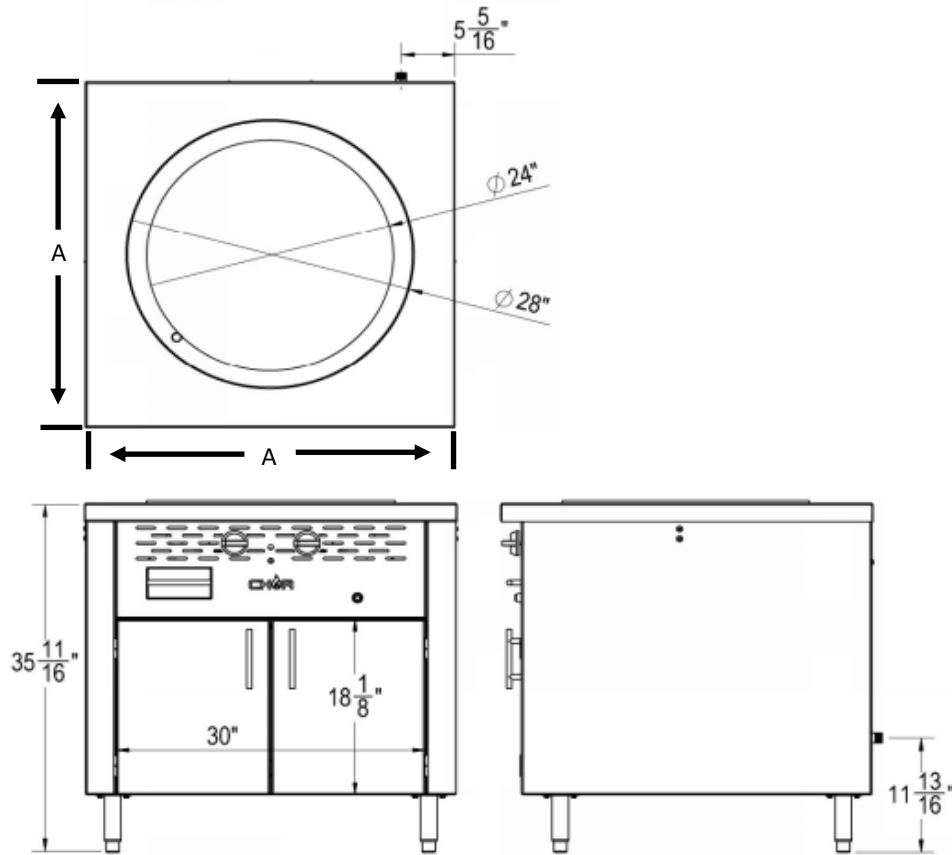

### INSTALLATION INSTRUCTIONS

1. A properly sized gas line must be provided. All units are internally regulated. DO NOT DUAL REGULATE
2. An adequate ventilation system is required for commercial use. DO NOT ATTEMPT TO OPERATE THIS EQUIPMENT WITHOUT IT.
3. Observe all local and national codes.
4. Proper combustion requires this unit to remain on casters or legs
5. This appliance is manufactured for commercial use ONLY. It is NOT intended for residential indoor use.
6. We upgrade our products regularly and in doing so, materials, specifications, and model numbers are subject to change without notice.

**CHAR Products, LLC**

Ph. 702-489-9888

Fax. 702-489-9898

Website: [www.charprd.com](http://www.charprd.com)

Email: [info@charprd.com](mailto:info@charprd.com)

2915 Losee Rd. Ste 106

N. Las Vegas, NV 89030