



APPLIANCES WITH SOUL®

# CHURRASCO GAS FUEL SPECIFICATION SHEET



## SPECIFICATIONS

The gas fueled CHAR Churrasco Broiler is available in single tier configurations in four different sizes. Each comes with rotating spits. A proven industrial gear motor offers years of uninterrupted operation of the rotating spits. To ensure performance and longevity these units are constructed entirely of 304 stainless steel and have a ceramic cloth exterior.

- See spec sheets for cabinet and table bases
- Must select length 36", 48", 60", 72"
- Must select gas type (LP) for Propane (NG) for Natural Gas



CHAR Products, LLC

Ph. 702-489-9888

Fax. 702-489-9898

Website: www.charprd.com

Email: info@charprd.com

2915 Losee Rd. Ste 106

N. Las Vegas, NV 89030

ITEM NO	
QUANTITY	
JOB NAME	
JOB NO	

## PART NUMBER DESIGNATION

**CP-GFG-CHU-** - - -

Length

Gas type (LP) for Propane (NG) for Natural Gas

Option code from option list

## STANDARD FEATURES

- 14 gauge stainless steel body
- Ceramic cloth insulated body
- Multiple gas control valves for precise heat control
- Over head resting rack
- Removable drip pans
- Adjustable leveling feet
- Skewers included
- 1/2" thick laser cut removable steel grates
- 3/4" gas connection
- Cleaning kit
- Appropriate gas regulator (for gas type selected)
- Two year warranty parts and labor

## OPTIONS

OPTION CODE	DESCRIPTION
FQD	48" FLEX QUICK DISCONNECT
RPS	REMOVABLE 8" PLATE SHELF
SSG	STAINLESS STEEL GRATE
RF	ROTISSERIE FORKS
PSC	PLATE SHELF 1/6 PAN CONDIMENT INSERTS

CONSULTANT APPROVAL:

\_\_\_\_\_



MODEL #	LENGTH A	FUEL LINE SIZE	ELECTRIC	BTU INPUT	SHIPPING WEIGHT
CP-GFG-CHU-36-__-__	36"	3/4"	120V-1PH-10A	66,000	656 LBS.
CP-GFG-CHU-48-__-__	48"	3/4"	120V-1PH-10A	115,500	874 LBS.
CP-GFG-CHU-60-__-__	60"	3/4"	120V-1PH-10A	148,500	1,093 LBS.
CP-GFG-CHU-72-__-__	72"	3/4"	120V-1PH-10A	165,000	1,311 LBS.

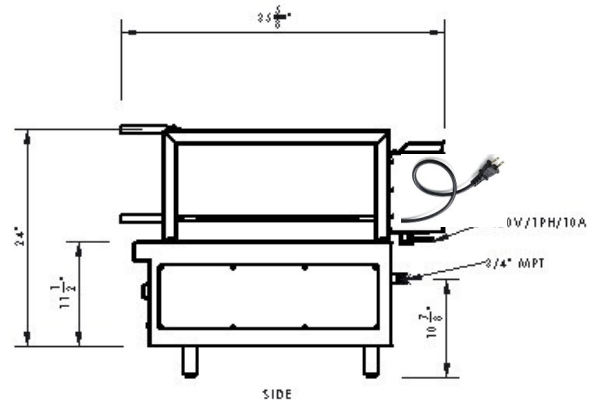
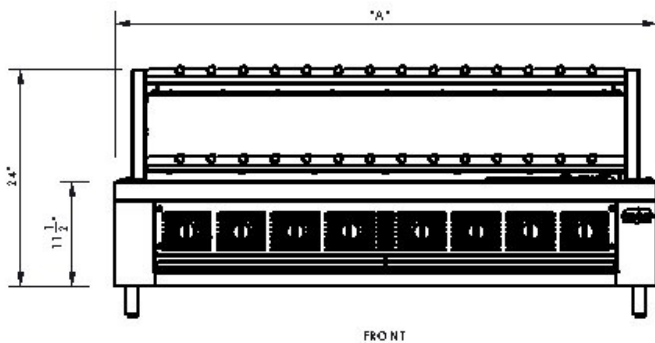
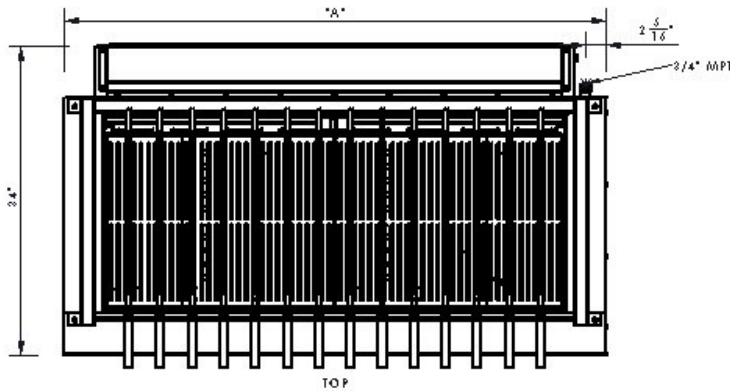

### INSTALLATION INSTRUCTIONS

1. A properly sized gas line must be provided. All units are internally regulated. DO NOT DUAL REGULATE.
2. An adequate ventilation system is required for commercial use. DO NOT ATTEMPT TO OPERATE THIS EQUIPMENT WITHOUT IT.
3. Observe all local and national codes.
4. Proper combustion requires this unit to remain on 3" legs.
5. This appliance is manufactured for commercial use ONLY. It is NOT intended for residential indoor use.
6. We upgrade our products regularly and in doing so, materials, specifications, and model numbers are subject to change without notice.

**CHAR Products, LLC**

Ph. 702-489-9888

Fax. 702-489-9898

Website: [www.charprd.com](http://www.charprd.com)

Email: [info@charprd.com](mailto:info@charprd.com)

2915 Losee Rd. Ste 106

N. Las Vegas, NV 89030